

Installation and operating instructions

BPW Landing gear
BPW Drawbar support



Contents

1.1 General safety notes

Landing gear	◎ 1	Landing gear	Page 2
	1.1	General safety notes	Page 2
	1.2	Use for intended purpose	Page 3
	1.3	Installation	Page 4
	1.4	Operation	Page 5
	1.4.1	Parking the trailer vehicle	Page 6
	1.4.2	Coupling the trailer	Page 7
	1.4.3	Loading the supported trailer vehicle	Page 7
	1.5	Lubrication and maintenance work	Page 8
	1.6	Technical data	Page 10
	1.6.1	BPW type plate	Page 11
	◎ 2	Drawbar support	Page 13
	2.1	General safety notes	Page 13
	2.2	Use for intended purpose	Page 13
	2.3	Installation	Page 14
	2.4	Operation	Page 15
	2.4.1	Parking the trailer vehicle	Page 15
	2.4.2	Coupling the trailer	Page 15
	2.4.3	Loading the supported trailer vehicle	Page 15
	2.5	Lubrication and maintenance work	Page 16
2.6	Technical data	Page 18	
2.6.1	BPW type plate	Page 19	

1.1 General safety notes

- All work must be carried out by trained specialist operatives in approved specialist workshops and authorised specialist organisations, which possess all the tools and knowledge required for carrying out this work. A pre-condition for carrying out installation, maintenance and repair tasks is having successfully completed a course of training as a motor vehicle mechanic with experience in repairing trailers and semitrailers.
- The vehicle must be secured against rolling away when carrying out repairs. Adhere to the valid safety instructions for carrying out repairs to commercial vehicles, particularly the safety instructions for jacking up and securing the vehicle.
- Adhere to any local safety instructions.
- The relevant operating and service instructions as well as safety instructions of the vehicle manufacturer or of the other vehicle component manufacturers must be followed.
- Only carry out repair work with protective clothing (gloves, protective shoes, safety goggles etc.) and the recommended tools.
- All replaced components must be recycled or disposed of in accordance with the applicable environmental protection provisions, laws and instructions.
- Bolts and nuts must be tightened with the prescribed tightening torque.
- The road traffic and accident prevention regulations issued by the professional associations must be followed.

Valid: 01.06.2017

5th edition

Subject to change without notice.

Current versions and additional information can be found online at www.bpw.de.

Landing gear 1

Use for intended purpose 1.2

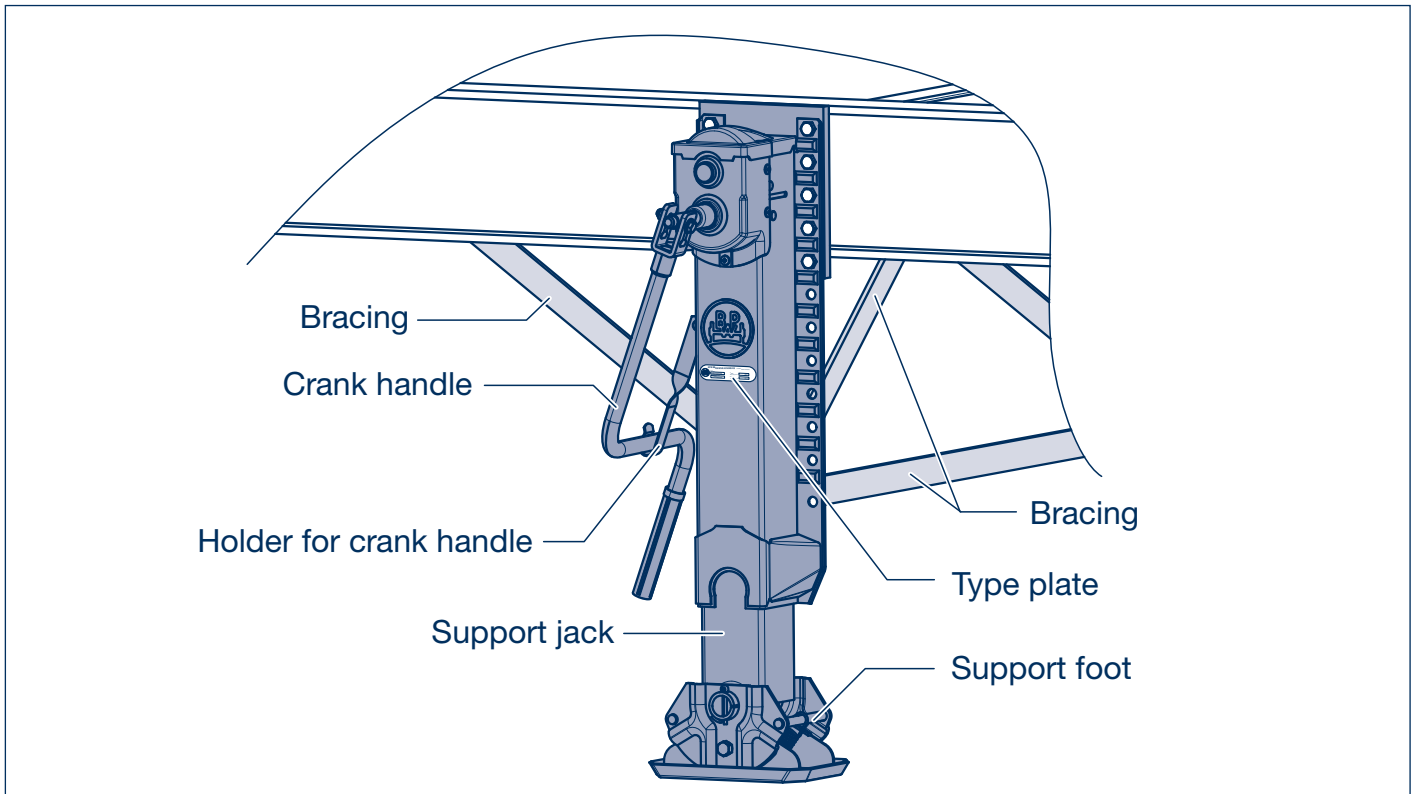

These BPW support jacks are intended for installing on a trailer vehicle. They provide support for the uncoupled trailer or semi-trailer, as well as for adjusting their height during the coupling procedure.

The support jacks can be used with laden or unladen vehicles.

The loading of an unhitched vehicle is permitted, provided that the relevant safety instructions are followed.

The vehicle must not be used on the road until it has been established that the trailer vehicle and landing gear comply with the road traffic regulations of the country concerned.

The landing gear may only be used if the relevant operating and service regulations of the vehicle manufacturer and the landing gear are observed. Operating the vehicle with damaged landing gear is prohibited.



Safety notes are indicated by a pictogram in these installation and operating instructions. These notes must be adhered to or followed in all cases.

1 Landing gear

1.3 Installation

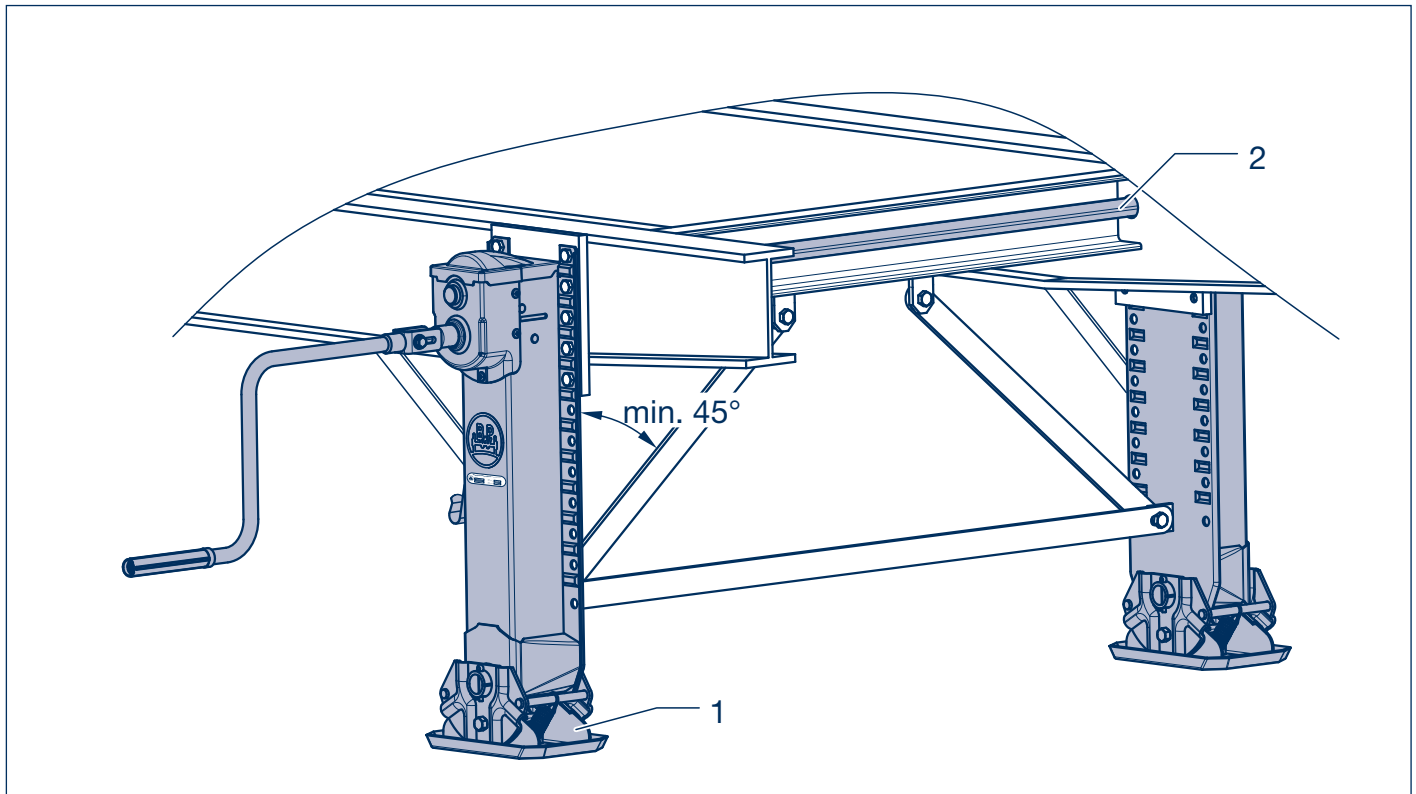

- [1] Screw in both support jacks (1) as far as they will go. This will ensure that both supports are positioned in parallel when they are extended.
- [2] Align the supports so that they are at a right angle to the frame and parallel to each another.
- [3] Measure the length of the connecting shaft (2) and adjust this accordingly.
- [4] Install the connecting shaft without jamming. A sliding gap of 8 ± 3 mm must be maintained. Jamming of the connecting shaft may impede ease of movement.
- [5] Screw each support to the frame with at least 10 hexagonal M 16-8.8 bolts, hexagonal nuts and ring washers.
- [6] Fit the bracing members between the legs and to the rear of each leg. Ensure that an angle of at least 45° to the support is maintained while doing this. Screw on the braces likewise with hexagonal M 16-8.8 bolts, hexagonal nuts and ring washers.
- [7] Tighten all securing bolts with a torque wrench to the prescribed tightening torque of 190 Nm (175 - 210 Nm).
- [8] Install the holder to secure the crank handle. For safety reasons, the crank handle must be mounted in the holder while the vehicle is in motion.



Carry out a function check after installing the landing gear. The spindle must be turn easily during this and the supports must both be touching the ground at the same time.

Uneven loading of the supports will lead to damage.

All warranty claims against the manufacturer and the supplier of the landing gear will be validated if installation is not carried out properly.



Operating safety notes

- The landing gear must only be operated by authorised personnel.
- Before operating the landing gear, the vehicle must always be secured against rolling away.
- No persons must be present beneath the vehicle during hitching and unhitching and when a vehicle is being supported.
- No persons must be present beneath the vehicle during the coupling procedure.
- Fast or slow gear must always be engaged.
- Care must be taken to avoid handle kick-back by completing the turning movement slowly.
- While the vehicle is in motion:
 - The crank handle must be installed and mounted in the holder
 - The landing gear must be completely retracted
 - The landing gear must be in a proper condition, with any defective support equipment having been repaired or replaced.
- When the vehicle is being supported, care must be taken that:
 - The ground underneath is sufficiently firm, with a suitable base being provided if necessary.
 - The ground must be even
 - The support foot must be freely movable
 - The upper and lower hoist limiters are not overwound.

1 Landing gear

1.4 Operation

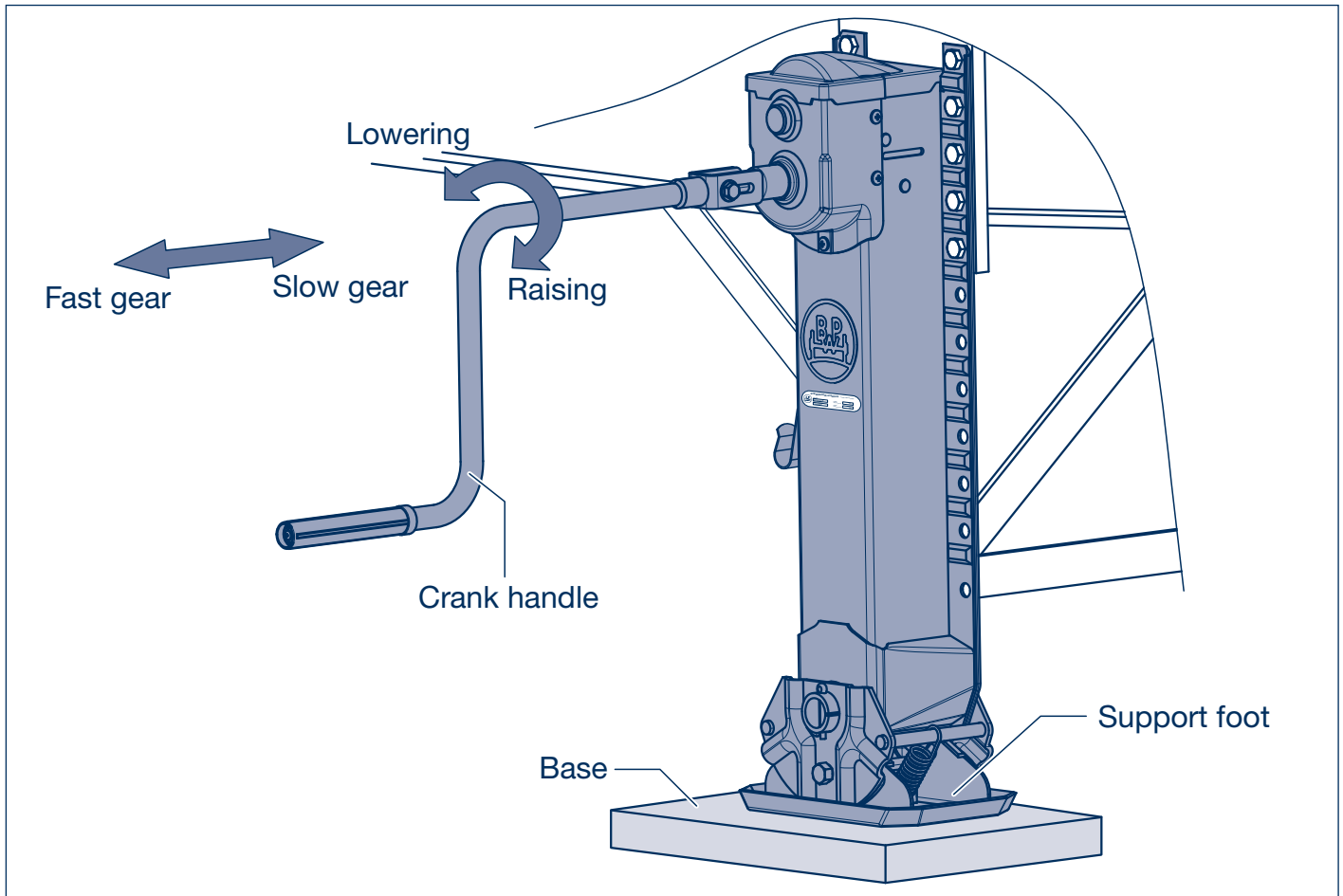

1.4.1 Parking the trailer vehicle

- [1] Park the trailer vehicle on a firm and level surface, using a base if necessary.
- [2] Secure the vehicle from rolling away.
- [3] Check the landing gear for damage and repair before use if necessary.
- [4] Remove the crank handle from the holder and pull out until the locking mechanism is engaged. The switching procedure is made easier with a slight turning movement.
- [5] Turn the crank handle clockwise, therefore extending the support in fast gear until it is just above the ground. The fast gear enables the clearance height to be reached quickly when extending or retracting without a load.
- [6] Switch to the slow gear. Press in the shaft with the crank handle until the locking mechanism is engaged. The switching procedure is made easier with a slight turning movement. The slow gear is used to raise or lower a laden or unladen trailer vehicle.
- [7] Unhitch the vehicle.
- [8] Mount the crank handle in the holder with the slow gear engaged.

1.4.2 Coupling the trailer

- [1] Take the crank handle from the holder.
- [2] Check whether the low gear is engaged and engage if required (see [6] page 6).
-  Take pressure off the crank handle slowly when the desired coupling height has been reached. There is a danger that the handle may kick back.
- [3] Turn the crank handle in slow gear:
 - Clockwise: to raise
 - Counter-clockwise: to lower.
- [4] Raise the trailer to the desired coupling height. Leave the spindle in slow gear.
- [5] Couple the trailer vehicle.
- [6] After coupling, fully retract the landing gear.
- [7] Mount the crank handle in the holder with slow gear engaged.

1.4.3 Loading the supported trailer vehicle

-  The supported trailer vehicle may only be loaded with a crane or driven onto with a fork-lift truck if the relevant safety instructions have been complied with.
Do not exceed the centre of gravity of the vehicle during the loading procedure, otherwise the drawbar trailer vehicle could tip over.

1 Landing gear

1.5 Lubrication and maintenance work

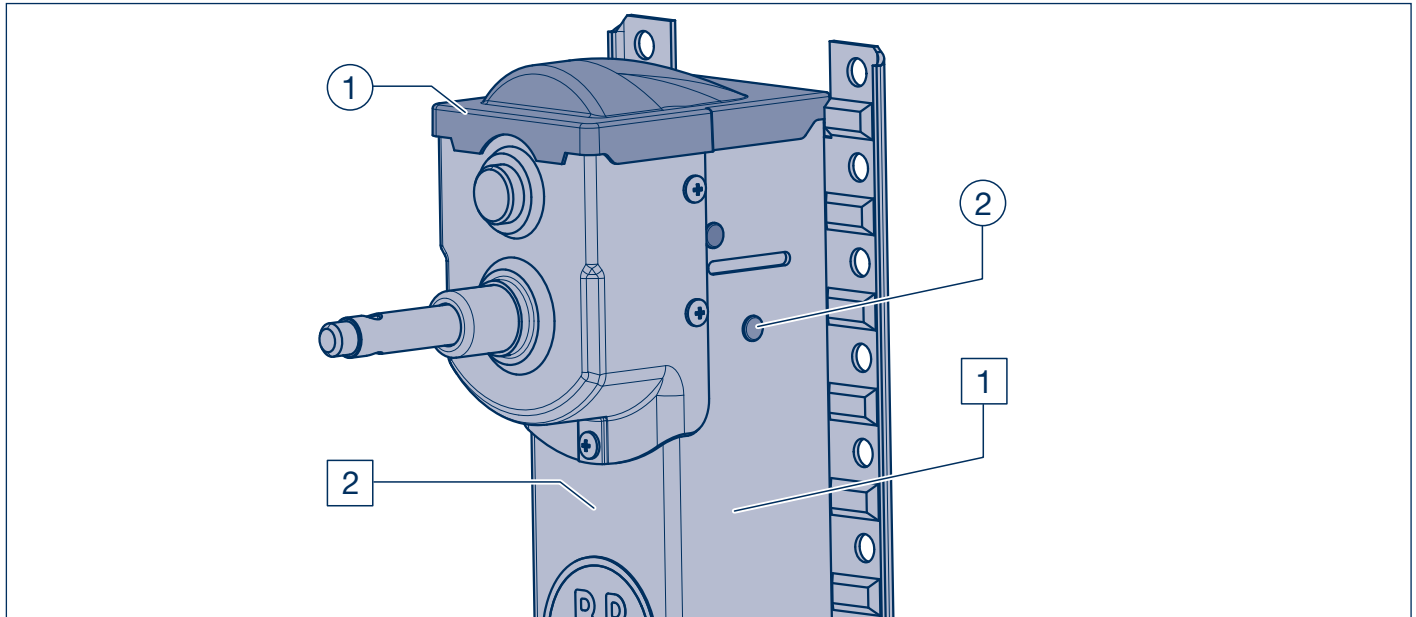

Overview of lubricating work		
		Initially after 3 years, then annually
①	Grease the transmission	①
②	Grease the spindle and spindle nut	②

Note: After cleaning the vehicle with high pressure cleansers, all lubrication points must be re-lubricated.

Overview of maintenance work			
		With every use	Initially after 3 years, then annually
1	Visual check of the landing gear for cracks and deformation	1	
2	Check the spindle and spindle nut for wear		2

Lubricating work

- ① **Greasing the transmission**
- Initially after 3 years, then annually -

Remove the upper transmission cover.
Fill the transmission housing with BPW special longlife grease ECO-Li 91.
Fit the transmission cover.

- ② **Grease the spindle and spindle nut**
- Initially after 3 years, then annually -

Screw out the jack as far as it will go. Remove the sealing plugs in the housing. Lubricate the spindle nut with approx. 200 g BPW special longlife grease ECO-Li 91. The spindle must be extended and then retracted again over the entire stroke. Insert sealing plugs.

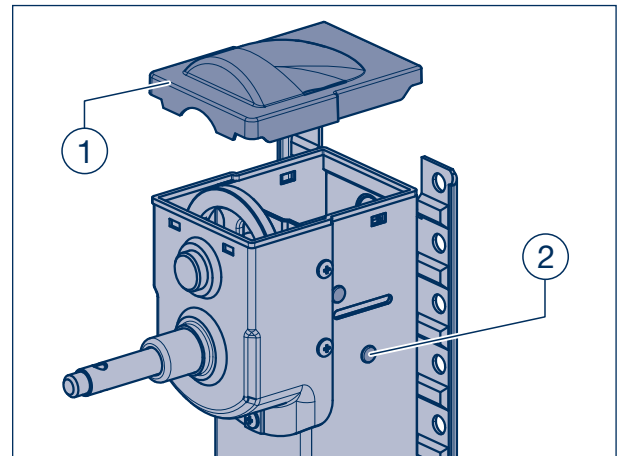

Maintenance work

- ① **Visual check of the landing gear for cracks and deformations**
- With every use -

Check landing gear and braces for damage, difficulty in movement, cracks and deformation.

Damaged landing gear must be repaired or replaced immediately.

Operating with defective landing gear is not permitted!

Check that support foot and support foot attachment are in good condition and undamaged.

- ② **Check the spindle and spindle nut for wear**
- Initially after 3 years, then annually -

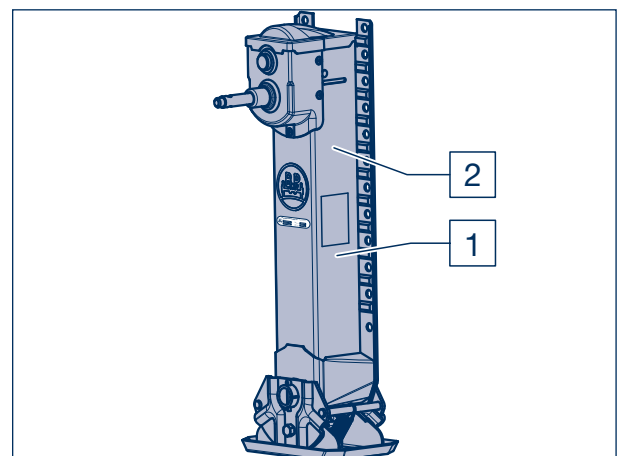

1 Landing gear

1.6 Technical data

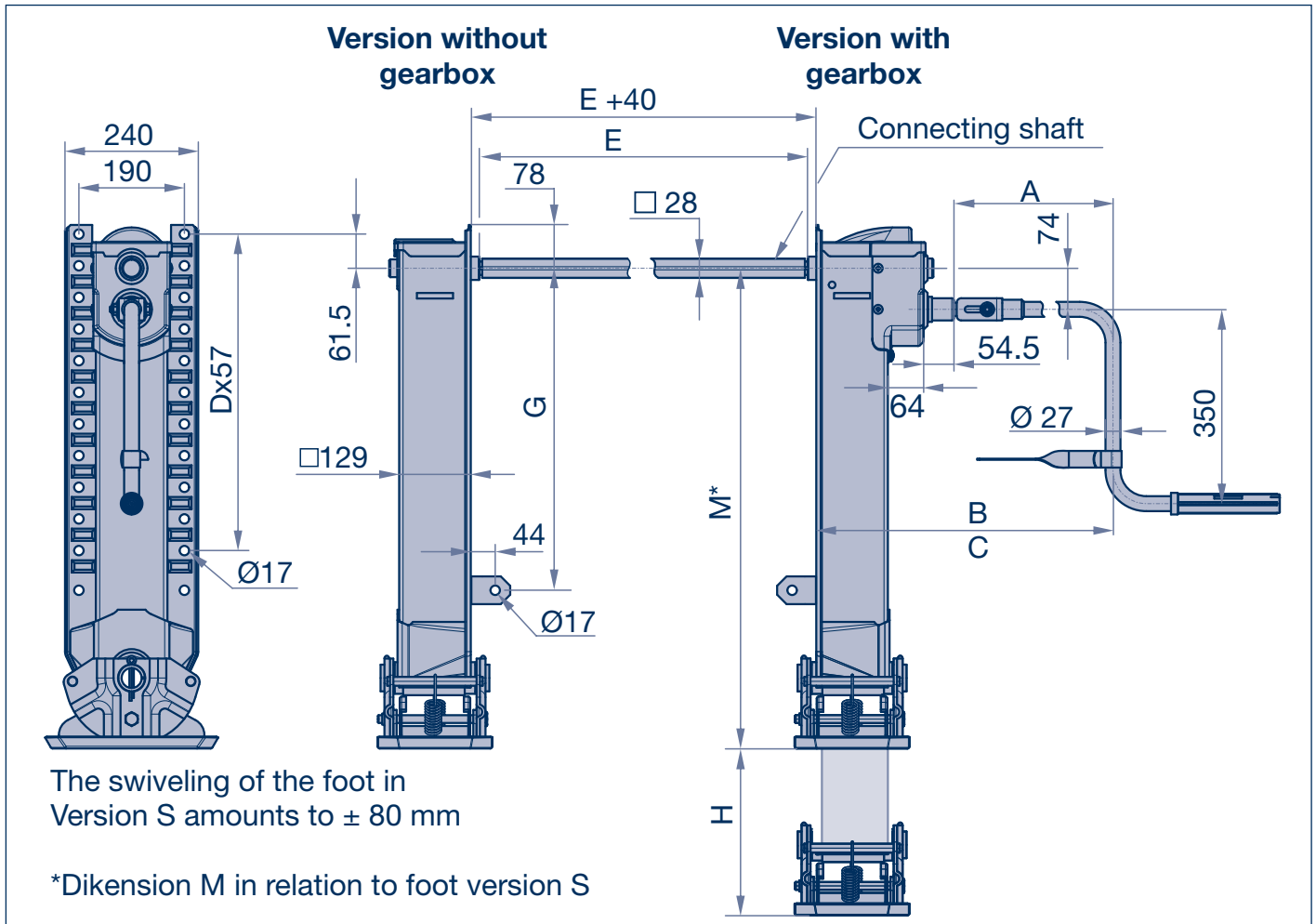

Support feet (without support jack)

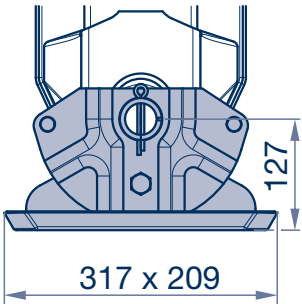
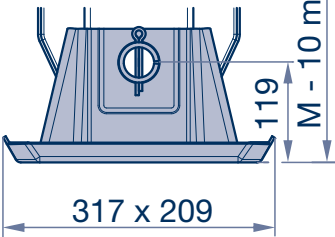
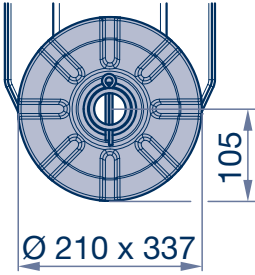
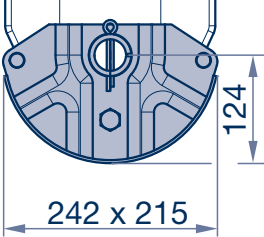
Version S	Version T	Version R	Version A
			
127	119 M - 10 mm	105	124
317 x 209	317 x 209	Ø 210 x 337	242 x 215
BPW code number: 02.3710.01.01	BPW code number: 02.3710.00.00	BPW code number: 02.3710.02.00	BPW code number: 02.3710.03.01

BPW support jacks

Length M	Dimen. H	Dimen. G	Quantity D	Foot design	BPW code number without gearbox	BPW code number with gearbox
650	350	380	7	T	02.3710.50.01	02.3710.51.01
				S	02.3710.52.01	02.3710.53.01
				W/o foot	02.3710.18.01	02.3710.19.01
700	400	430	8	T	02.3710.60.01	02.3710.61.01
				S	02.3710.62.01	02.3710.63.01
				W/o foot	02.3710.16.01	02.3710.17.01
750	420	480	9	T	02.3710.20.01	02.3710.21.01
				S	02.3710.22.01	02.3710.23.01
				W/o foot	02.3710.10.01	02.3710.11.01
800	470	530	9	T	02.3710.30.01	02.3710.31.01
				S	02.3710.32.01	02.3710.33.01
				W/o foot	02.3710.12.01	02.3710.13.01
850	520	580	10	T	02.3710.40.01	02.3710.41.01
				S	02.3710.42.01	02.3710.43.01
				W/o foot	02.3710.14.01	02.3710.15.01

Crank handles

Dimension A	Dimension B (slow gear)	Dimension C (fast gear)	BPW code number
450	715	740	02.1404.31.01

Connecting shaft

Dimension E	BPW code number
1500	02.4307.10.01

Other types upon request.



Note:
Other versions of BPW support jacks, support feet, hand cranks and connecting shafts are available by request.

1.6.1 BPW type plate



Technical data (per set):

Lifting capacity:	24 t
Static capacity:	50 t
Stroke per crank handle turn	
Slow gear:	0.8 mm
Fast gear:	9.6 mm
Crank force at 16 t load:	175 N

Drawbar support 2

General safety notes 2.1

Use for intended purpose 2.2

2.1 General safety notes

- All work must be carried out by trained specialist operatives in approved specialist workshops and authorised specialist organisations, which possess all the tools and knowledge required for carrying out this work. A pre-condition for carrying out installation, maintenance and repair tasks is having successfully completed a course of training as a motor vehicle mechanic with experience in repairing trailers and semitrailers.
- The vehicle must be secured against rolling away when carrying out repairs. Adhere to the valid safety instructions for carrying out repairs to commercial vehicles, particularly the safety instructions for jacking up and securing the vehicle.
- Adhere to any local safety instructions.
- The relevant operating and service instructions and the safety instructions of the vehicle manufacturer or of the other vehicle component manufacturers must be followed.
- Only carry out repair work with protective clothing (gloves, protective shoes, safety goggles etc.) and the recommended tools.
- All replaced components must be recycled or disposed of in accordance with the applicable environmental protection provisions, laws and instructions.
- Bolts and nuts must be tightened with the prescribed tightening torque.
- The road traffic and accident prevention regulations issued by the professional associations must be followed.

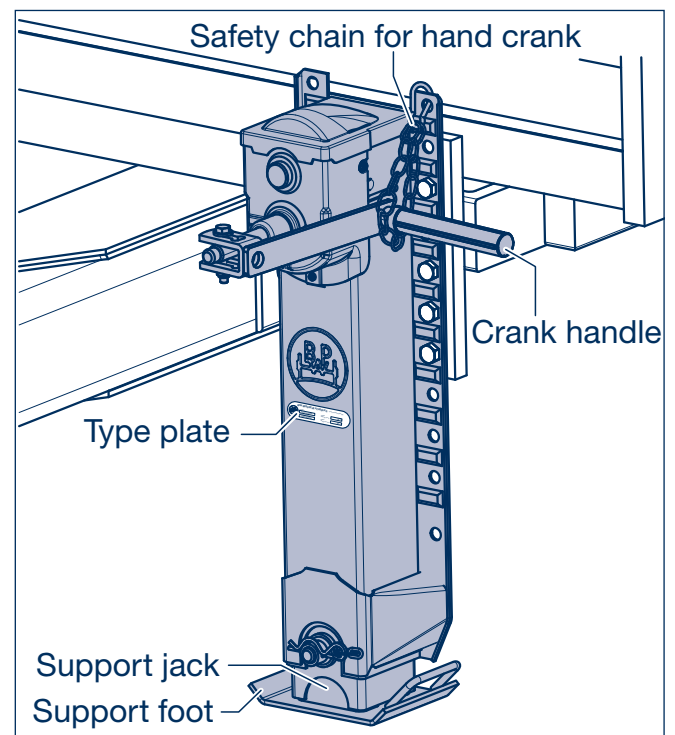

2.2 Use for intended purpose

These BPW drawbar supports are intended for installing on a trailer vehicle. They provide support for the uncoupled trailer or semi-trailer, as well as for adjusting their height during the coupling procedure.

The drawbar supports can be used with laden or unladen vehicles.

The loading of an unhitched vehicle is permitted, provided that the relevant safety instructions are followed.

The vehicle must not be used on the road until it has been established that the trailer vehicle and drawbar support comply with the road traffic regulations of the country concerned.

The drawbar supports may only be used if the relevant operating and service regulations of the vehicle manufacturer and the landing gear are observed.

Operating the vehicle with damaged drawbar support is prohibited.



Safety notes are indicated by a pictogram in these installation and operating instructions. These notes must be adhered to or followed in all cases.

2 Drawbar support

2.3 Installation

- [1] Align the supports so that they are at a right angle to the frame.
- [2] Screw each support to the frame with at least 10 hexagonal M 16-8.8 bolts, hexagonal nuts and ring washers.
- [3] Tighten all securing bolts to the prescribed tightening torque of 190 Nm (175 - 210 Nm) with a torque wrench.
- [4] Fit the carabiner with chain to secure the crank handle. For safety reasons, the crank handle must be mounted in the holder while the vehicle is in motion.



Carry out a function check after installing the landing gear. The spindle must turn easily during this. All warranty claims against the manufacturer and the supplier of the landing gear will be invalidated if installation is not carried out properly.

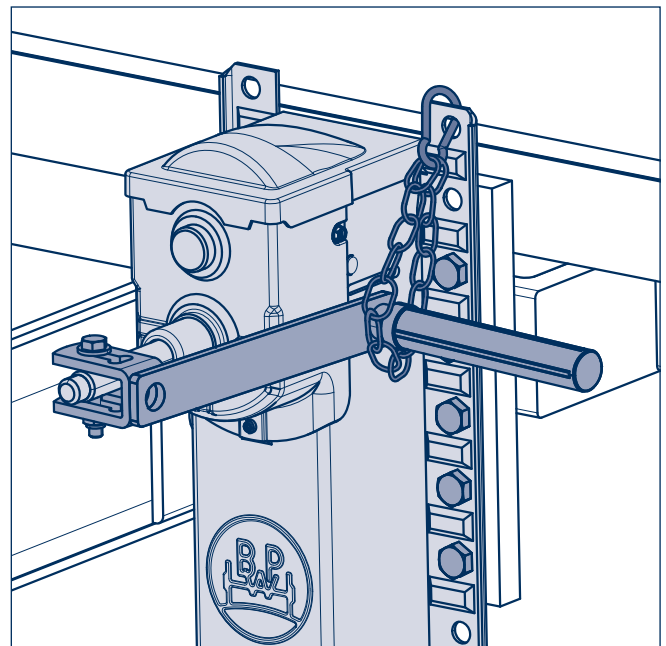

Operating safety notes

- The landing gear must only be operated by authorised personnel.
- Before operating the landing gear, the vehicle must always be secured against rolling away.
- No persons must be present beneath the vehicle during hitching and unhitching and when a vehicle is being supported.
- No persons must be present beneath the vehicle during the coupling procedure.
- Fast or slow gear must always be engaged.
- Care must be taken to avoid handle kick-back by completing the turning movement slowly.
- While the vehicle is in motion:
 - The crank handle must be installed and mounted in the safety chain
 - The drawbar support must be completely retracted
 - The drawbar support must be in a proper condition, with any defective support equipment having been repaired or replaced.
- When the vehicle is being supported, care must be taken that:
 - The ground underneath is sufficiently firm, with a suitable base being provided if necessary.
 - The ground must be even
 - The upper and lower hoist limiters are not overwound.

Operation 2.4

2.4.1 Parking the trailer vehicle

- [1] Park the trailer vehicle on a firm and level surface, using a base if necessary.
- [2] Secure the vehicle from rolling away.
- [3] Check the drawbar support for damage and repair before use if necessary.
- [4] Remove the crank handle from the safety chain and pull out until the locking mechanism is engaged. The switching procedure is made easier with a slight turning movement.
- [5] Turn the crank handle clockwise, therefore extending the support in fast gear until it is just above the ground. Fast gear allows the clearance height to be reached quickly when extending or retracting without a load.
- [6] Switch to the low gear. Press in the shaft with the crank handle until the locking mechanism is engaged. The switching procedure is made easier with a slight turning movement. Slow gear is used to raise or lower a laden or unladen trailer vehicle.
- [7] Unhitch the vehicle.
- [8] Mount the crank handle in the safety chain with slow gear engaged.

2.4.2 Coupling the trailer

- [1] Take the crank handle from the safety chain.
- [2] Check whether slow gear is engaged and engage if required (see [6] chapter 2.4.1).



Take pressure off the crank handle slowly when the desired coupling height has been reached. There is a danger that the handle may kick back.

- [3] Turn the crank handle in slow gear:
 - Clockwise: to raise
 - Counter-clockwise: to lower.
- [4] Raise the trailer to the desired coupling height. Leave the spindle in slow gear.
- [5] Couple the trailer vehicle.
- [6] After coupling, fully retract the landing gear.
- [7] Mount the crank handle in the safety chain with slow gear engaged.

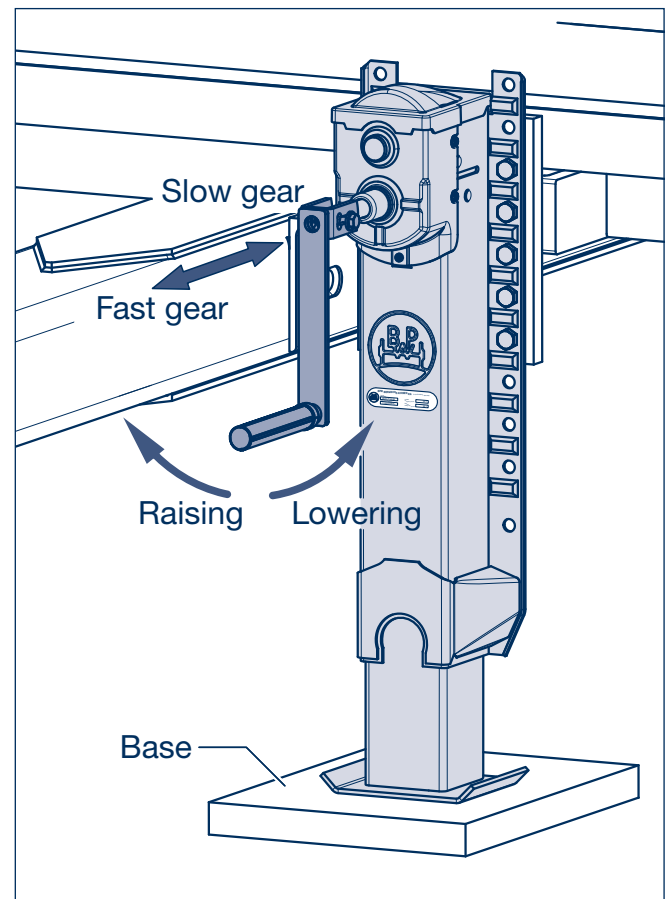

2.4.3 Loading the supported trailer vehicle



The supported trailer vehicle may only be loaded with a crane or driven on with a fork-lift truck, if the relevant safety instructions have been complied with.

Do not exceed the centre of gravity of the vehicle during the loading procedure, otherwise the drawbar trailer vehicle could tip over.

2 Drawbar support

2.5 Lubrication and maintenance work

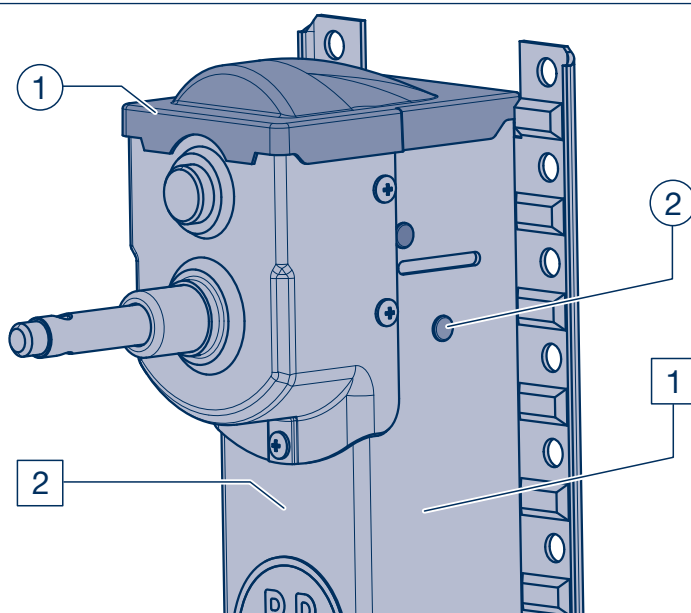

Overview of lubricating work		
		Initially after 3 years, then annually
①	Grease the transmission	①
②	Grease the spindle and spindle nut	②

Note: After cleaning the vehicle with high pressure cleansers, all lubrication points must be re-lubricated.

Overview of maintenance work			
		With every use	Initially after 3 years, then annually
1	Visual check of the drawbar support for cracks and deformation	1	
2	Check the spindle and spindle nut for wear		2

Lubricating work

- ① **Greasing the transmission**
- Initially after 3 years, then annually -

Remove the upper transmission cover.
Fill the transmission housing with BPW special longlife grease ECO-Li 91.
Fit the transmission cover.

- ② **Grease the spindle and spindle nut**
- Initially after 3 years, then annually -

Screw out the jack as far as it will go. Remove the sealing plugs in the housing. Lubricate the spindle nut with approx. 200 g BPW special longlife grease ECO-Li 91. The spindle must be extended and then retracted again over the entire stroke. Insert sealing plugs.

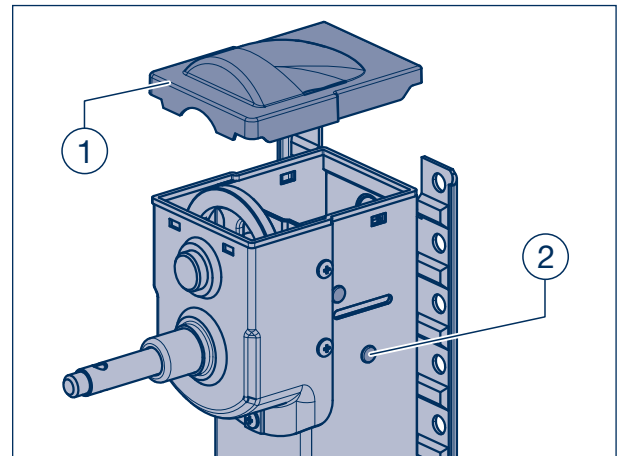

Maintenance work

- ① **Visual check of the drawbar support for cracks and deformation**
- With every use -

Check drawbar support for damage, difficulty in movement, cracks and deformation.

Damaged drawbar support must be repaired or replaced immediately.

Operating with defective landing gear is not permitted!

Check attachment of bolt for additional drop down height.

- ② **Check the spindle and spindle nut for wear**
- Initially after 3 years, then annually -

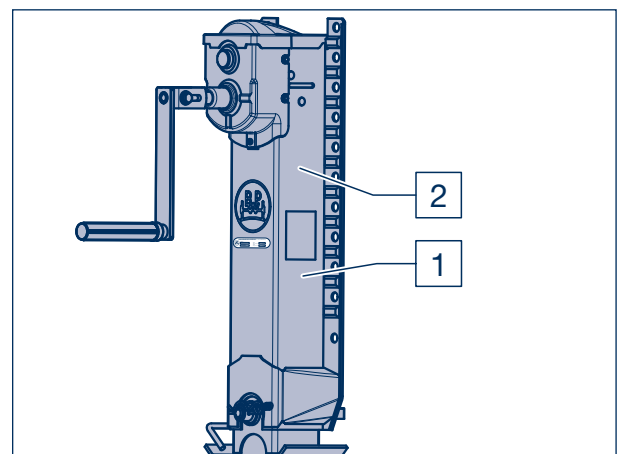

2 Drawbar support

2.6 Technical data

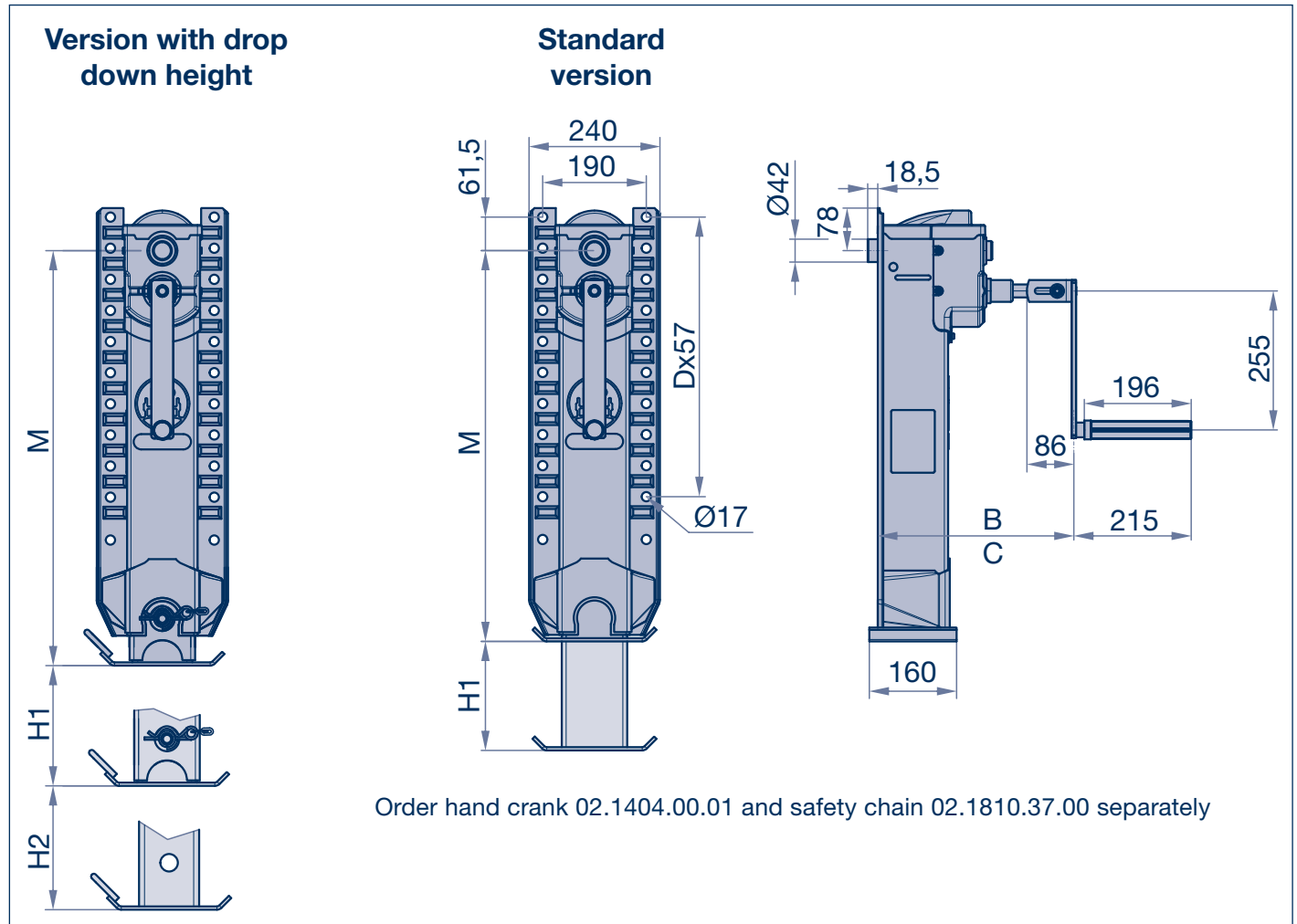

BPW drawbar supports

Version	Length M	Dimen. H1	Dimen. H2	Number D	Lifting capacity	Static capacity	BPW code number
Drawbar support, standard	715	470	--	9	12 t	25 t	02.3711.00.00
	665	420	--	9	12 t	25 t	02.3711.01.00
	620	375	--	8	12 t	25 t	02.3711.02.00
	570	325	--	7	12 t	25 t	02.3711.03.00
Drawbar support with drop down height	760	400	410	9	10 t	15 t	02.3711.11.00

Crank handles

Dimension B (slow gear)	Dimension C (fast gear)	BPW code number
328	362	02.1404.00.01

2.6.1 BPW type plate (example)



Technical data:

Lifting capacity:	12 t
Static capacity:	25 t
Stroke per crank handle turn	
Slow gear:	0.8 mm
Fast gear:	9.6 mm

For load information of other versions, see table on page 18.



BPW-BA-SV 37451701e

BPW is a globally leading manufacturer of intelligent running gear systems for trailers and semi-trailers. As an international mobility and system partner, we offer a wide range of solutions for the transport industry from a single source, from axle to suspension and brake to user-friendly telematics applications.

We thereby ensure outstanding transparency in loading and transport processes and facilitate efficient fleet management. Today, the well-established brand represents an international corporation with a wide product and service portfolio for the commercial vehicle industry. Offering running gear systems, telematics, lighting systems, composite solutions and trailer superstructures, BPW is the right system partner for automotive manufacturers.

BPW, the owner-operated company, consistently pursues one target: To always give you exactly the solution which will pay off. To this end, we focus our attention on uncompromising quality for high reliability and service life, weight and time-saving concepts for low operating and maintenance costs as well as personal customer service and a close-knit service network for quick and direct support. You can be sure that with your international mobility partner BPW, you always use the most efficient method.

Your partner on the path to economic viability



BPW Bergische Achsen Kommanditgesellschaft

Postbox 12 80 · 51656 Wiehl, Germany · Phone +49 (0) 2262 78-0

info@bpw.de · www.bpw.de