



Series	Air suspension axles and suspensions	Axle load	Trailing arm 100 mm wide	Air bag	Axle type with drum brake SN 4220	Ride height FH (mm)	to drawing	
SLO		Air suspension axles	12t	Single leaf 1x57	36K / 36	HSF... HZF...	415 - 560	Blatt 1a
				Double leaf 2x43			445 - 585	Blatt 2a
		Steering axles LL with trailing arm	12t	Single leaf 1x57	36K / 36	HSFH...LL	425 - 560	Blatt 4a
		Two-sided lifting device	12t					Blatt 7
SLM		Air suspension axles	12t	Single leaf 1x57	36K / 36	HSF... HZF...	320 - 500	Blatt 8a
				Double leaf 2x43			350 - 500	Blatt 9a
		Steering axles LL with trailing arm	12t	Single leaf 1x57	36K / 36	HSFH...LL	330 - 500	Blatt 11a
		Two-sided lifting device	12t					Blatt 14
SLU		Air suspension axles	12t	Single leaf 1x57	36	HSF... HZF...	235 - 335	Blatt 15a
				Double leaf 2x43			235 - 335	Blatt 16a
		One-sided lifting device	12t					Blatt 19

Rev. 3 (7) 16.11.2016  
Subject to change without notice.





Weight variations are within the permitted DIN tolerances for the production process, given in kg.

Series	to drawing	Line	Weight of air suspension parts	Weight of axle mounting	SP 1820		SP 2040			SP 2090
					FM 900	FM 980	FM 980	FM 1200	FM 1300	FM 1030
SLO	Sheet 1a	1	151	22	416	416		420	420	
		2	153							
		3	157							
	Sheet 2a	1	170	19	416	416		420	420	
		2	172							
		3	176							
SLOLL	Sheet 4a	1	151	22			561			572
		2	153							
		3	157							
SLM	Sheet 8a	1	144	22	416	416		420	420	
		2	146							
		3	157							
		4	158							
		5	158							
	Sheet 9a	1	170	19	416	416		420	420	
		2	180							
		3	180							
SLMLL	Sheet 11a	1	144	22			561			572
		2	146							
		3	157							
		4	158							
		5	158							
SLU	Sheet 15a	1	157	29	404	404		408	408	
		2	157							
		3	157							
	Sheet 16a	1	176	26	404	404		408	408	
		2	176							
		3	176							
Lifting	Sheet 7, 14				Two-sided lifting device					39
	Sheet 19				One-sided lifting device					41

Air suspension parts
+ Axle mounting
+ Axle
+ Additional weight
= <b>Total weight</b>

Rev. 3 (7) 16.11.2016

Subject to change without notice.



Series	to drawing	Trailing arm				Axle load kg	Height of centre of gravity max.				
		05.082..	Thickness	L1	L2		Spring centre FM				
							900	980	1030	1200	1300
SLO	Sheet 1a	..13.75.1	1x57	500	380 / 405	10000	2400	2550	---	3000	3200
						12000	2050	2150	---	2500	2700
	Sheet 2a	..12.68.0	2x43	500	355 / 380	10000	2800	2950	---	3500	3700
						12000	2350	2500	---	2900	3100
	Sheet 4a	..13.75.1	1x57	500	380 / 405	10000	---	2550	2650	---	---
						12000	---	2150	2250	---	---
SLM	Sheet 8a	..13.83.1	1x57	500	380 / 405	10000	2400	2550	---	3000	3200
						12000	2050	2150	---	2500	2700
	Sheet 9a	..13.33.0	2x43	500	355 / 380	10000	2800	2950	---	3500	3700
						12000	2350	2500	---	2900	3100
	Sheet 11a	..13.83.1	1x57	500	380 / 405	10000	---	2550	2650	---	---
						12000	---	2150	2250	---	---
SLU	Sheet 15a	..13.75.1	1x57	500	380 / 405	10000	2100	2250	---	2750	2950
						12000	1750	1850	---	2250	2400
	Sheet 16a	..13.36.0	2x43	500	355 / 380	10000	2400	2550	---	3050	3300
						12000	1950	2100	---	2500	2700

**Determining the heights of centre of gravity for axle units with steered axles.**

$$\frac{\text{Heights of centre of gravity of rigid axles} + \text{Heights of centre of gravity of steering axles}}{\text{Number of axles}} = \text{Height of centre of gravity}$$

**Example**

$$\frac{2500 + 2500 + 2200}{3} = 2400$$

Calculation reference:

0,4 g transverse acceleration lateral body tilt approx. 3.5 degrees  
without taking into consideration the tilt limit and the tyre deflection.

Rev. 4	(7)	22.11.2016
Subject to change without notice.		



	Hanger bracket height ST=184	Hanger bracket height ST=268	Hanger bracket height ST=350
<b>Rigid Version</b> Spring bolt assembly : 05.857.00.54.0	<p>05.375.68.88.0</p>	<p>05.375.68.89.0</p>	<p>05.375.69.13.0</p>
<b>Adjustable Version</b> Spring bolt assembly : 05.857.00.55.0	<p>05.375.68.52.0</p>	<p>05.375.68.51.0</p>	<p>05.375.69.17.0</p>

**Note:**

The hanger brackets and the frame must be reinforced so that the forces applied can be absorbed. See the current BPW installation instructions.

Rev. 4 (7) 01.02.2018  
Subject to change without notice.



Advice	Conditions	Axle load	Air suspension series	Tyre S = Single tyres Z = Twin tyres	Spring centre	Trailing arm		Shock absorber	Air bag	Axle beam	Axle connection	Comments
						70 mm	100 mm					
1	On-Road use	9 t	EAC	S	≥ 1200	Guide link		Standard	Ø 300 / Ø 360	120 x 10	Clamped	For container and coil carrier trailers, the use of air bag stroke limitation is necessary.
2			AL II			1 x 56						
3				Z	< 1200	1 x 62						
4		S / Z		≥ 1100								
5		10 t	Z	< 1100	1 x 65							
6			11.8 t (only with SN 4220)	S / Z								
7	Off-Road use	9 t	EAC HD	S	≥ 1200	Guide link		HD	Ø 300 / Ø 360 with reinforced airbag plate	120 x 10	Clamped	Tipper trailers require the use of a lowering device or stroke limitation.
8			AL II			1 x 62						
9		S / Z			1 x 65	Standard / HD	Ø 360 with reinforced airbag plate	120 x 15				
10									10 t			
11		10 t - 12 t	SL			1 x 57 / 2 x 43		120 x 17	150 x 16	Welded		

**Observations:**

- Deviations from the required features may affect the ECO-Plus warranty. Your BPW contact is at your disposal for further information and personal advice.
- The data sheets of the BPW air suspension must be observed for the exact specification of the air spring modules according to the application areas and the possible combinatorial function of the components mentioned (incl. TE-3075.0).
- Disc cover plate for disc brakes  
 On-road:            General, no cover plate is necessary for on-road use.  
 Rugged conditions:   Cover plates are recommended for use in rugged conditions. Rugged conditions are the off-road use as well as difficult on-road conditions (e.g. high amounts of dirt, ice or snow).

Rev. 0	(7)	23.04.2018
Subject to change without notice.		



TE-3075.0

(V1, 22.06.2017)

axle seats	axle beam cross section							
	120x10	120x15	120x17	120 massiv	150x16	150x20	150x24	150 massiv
clamped	ok	ok	ok					
welded		ok	ok	ok	ok	ok	ok	ok

trailing arm		axle beam cross section							
		120x10	120x15	120x17	120 massiv	150x16	150x20	150x24	150 massiv
70x56 70x62	L1=500 L1=550	⊠	⊙						
70x62	L1=500	⊠ <sup>1)</sup>	⊙	⊙	⊠				
70x65	L1=500		⊙	⊠	⊠				
70x62/65 (3D)	L1=500		⊙	⊙	⊠				
70x62	L1=620 <sup>2)</sup>	⊠	⊠						
2x 70x56	L1=690		⊠	⊠	⊠				
2x 70x48	L1=550		⊙	⊠	⊠				
2x70x52	L1=500		⊙	⊠	⊠				
100x57	L1=500					⊠	⊠		
2x100x43	L1=500					⊠	⊠		
2x100x51	L1=550					⊠	⊠	⊠	⊠

⊠	combination not feasible / not permitted
⊠	only clamped axle seat arrangement
⊙	clamped and welded axle seat arrangement possible consider axle load and spring centre acc. to CoG heights
⊠	only welded axle seat arrangement
<sup>1)</sup>	only if spring centre is between 980 and 1100, difference track / spring centre max. 850
<sup>2)</sup>	difference track / spring centre similar to welded axle seat arrangement

feasible centre of gravity heights see TE-1312.0

deviations have to be discussed with BPW technical department

Rev. 0 (7) 01.02.2018

Subject to change without notice.

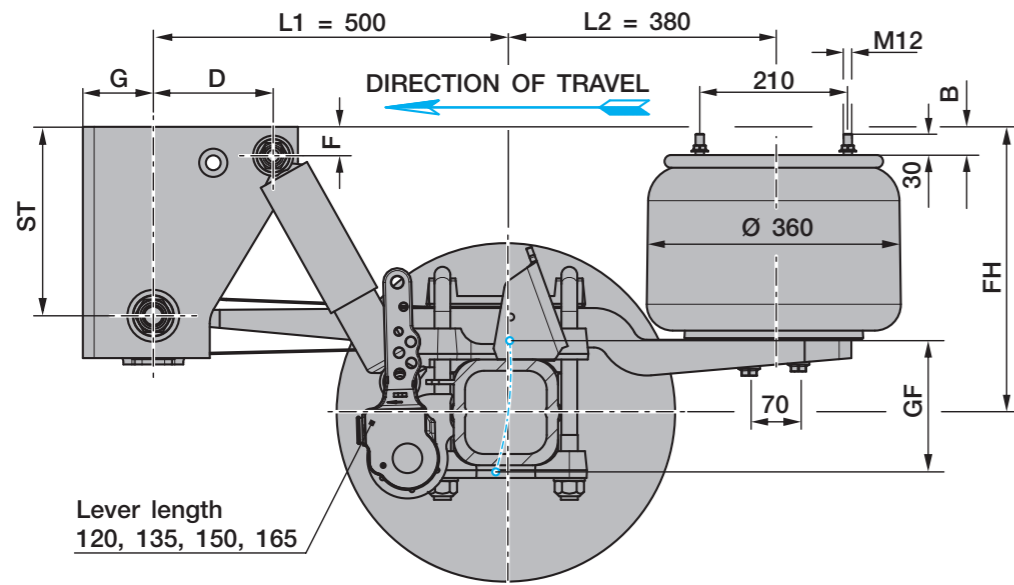

10 bolts M 22 x 1.5  
DIN 74361 part 1 or part 3

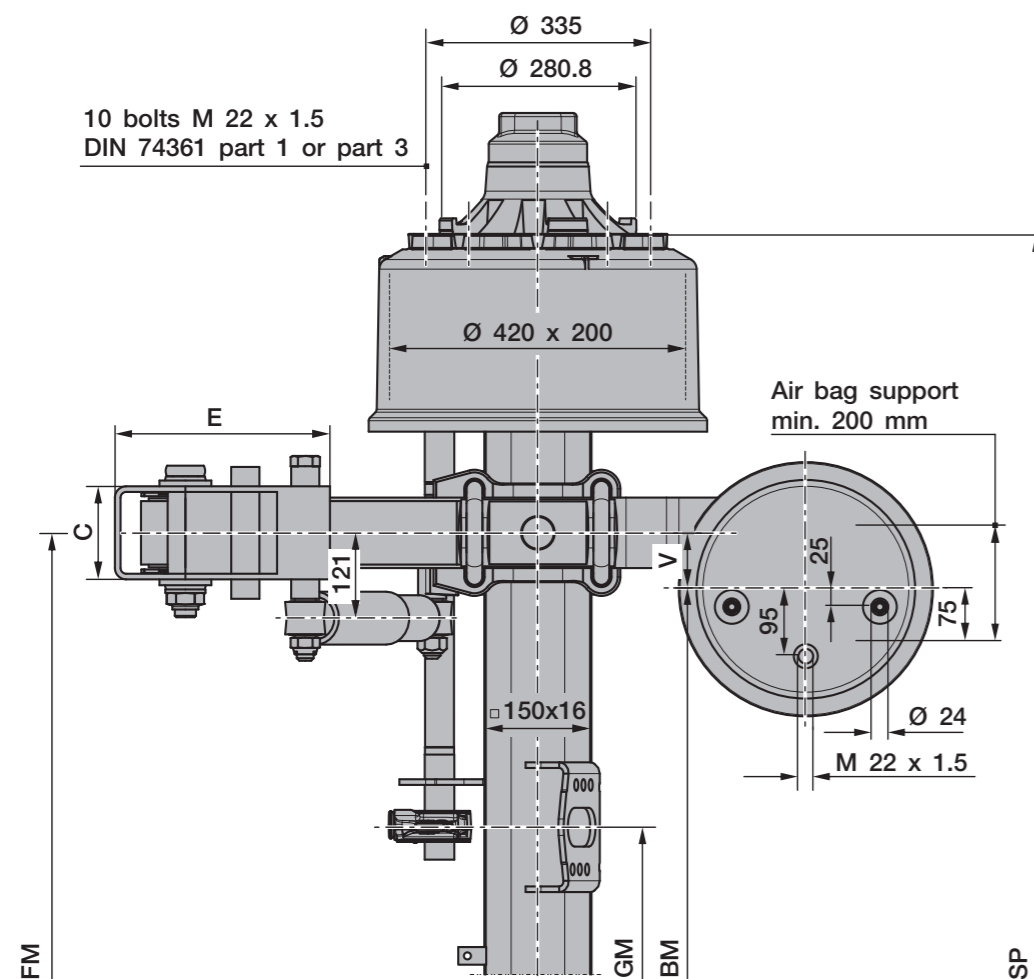

Line	Series	adjustable ride height FH					Total spring travel GF <sup>1)</sup>	Air bag type BPW	Shock absorber 02.37...	Hanger bracket				Shock absorber mounting		Packer <sup>2)</sup> B
		for single axles	for axle units	min. FH with axle raised	empty without air	loaded without air				ST	C	E	G	D	F	
1	SLO	415 - 455	425 - 455	455	355	340	190	36K	...22.83.02	268	130	305	100	170	41	---
2	SLO	445 - 500	455 - 500	485	385	370	220	36	...22.83.02	268	130	305	100	170	41	---
3	SLO	510 - 560	520 - 560	550	450	435	220	36	...22.88.02	350	130	355	100	75	115	60

<sup>1)</sup> Lifting heights acc. to TD-1242.0  
<sup>2)</sup> The packer is not included in supplied package.

Axle type	Track SP	Spring centre FM	Booster bracket centre GM	Air bag centre BM V=80	Brake cylinder <sup>3)</sup>	Tyres recommended <sup>5)</sup>
HSFSLO 12010	2040	1200	365	1040	M / F	425/65 R22,5 445/65 R22,5
		1300		1140		
HZFSLO 12010	1820	900	261	740	M / (F) <sup>4)</sup>	275/70 R22,5 <sup>6)</sup> 295/80 R22,5 <sup>7)</sup>
		980		820		

<sup>3)</sup> M = for diaphragm cylinder / F = for spring brake cylinder

<sup>4)</sup> Use F-booster bracket with spring brake cylinder.

<sup>5)</sup> The load rating of the tyre entered in the drawing is unrelated to the axle load capacity. It is dependent on the information from the tyre manufacturer.

<sup>6)</sup> Track = 1820 / spring centre = 980: rim 22.5 x 7.50 with centre distance = 320 mm

<sup>7)</sup> Tyre 295/80 R22.5 only possible with track = 1820 / spring centre = 900.

- Recommended use for BPW chassis and suspensions: As specified in current BPW warranty documents.
- Max. inclination angle of the semitrailer under full load and lowest adjustable ride height ±1°
- With trailing arm L1=500 / L2=380, bag pressures acc. to TE-1188.0 sheet 11
- The hanger brackets, air bag supports and the frame must be reinforced so that the forces applied can be absorbed. See the current BPW installation instructions.

Rev. 4 (7) 01.02.2018  
Subject to change without notice.

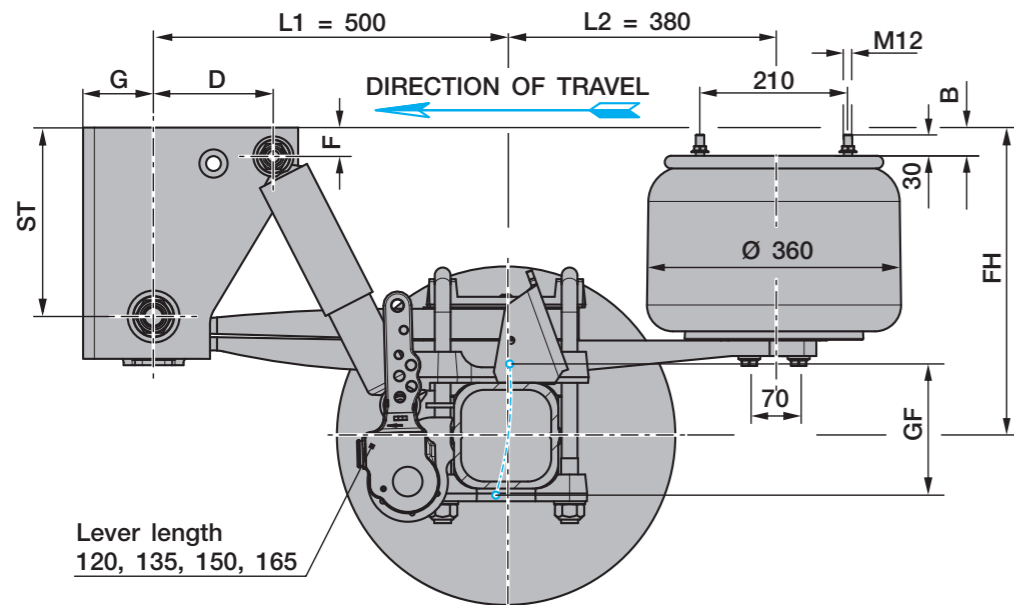

10 bolts M 22 x 1.5  
DIN 74361 part 1 or part 3

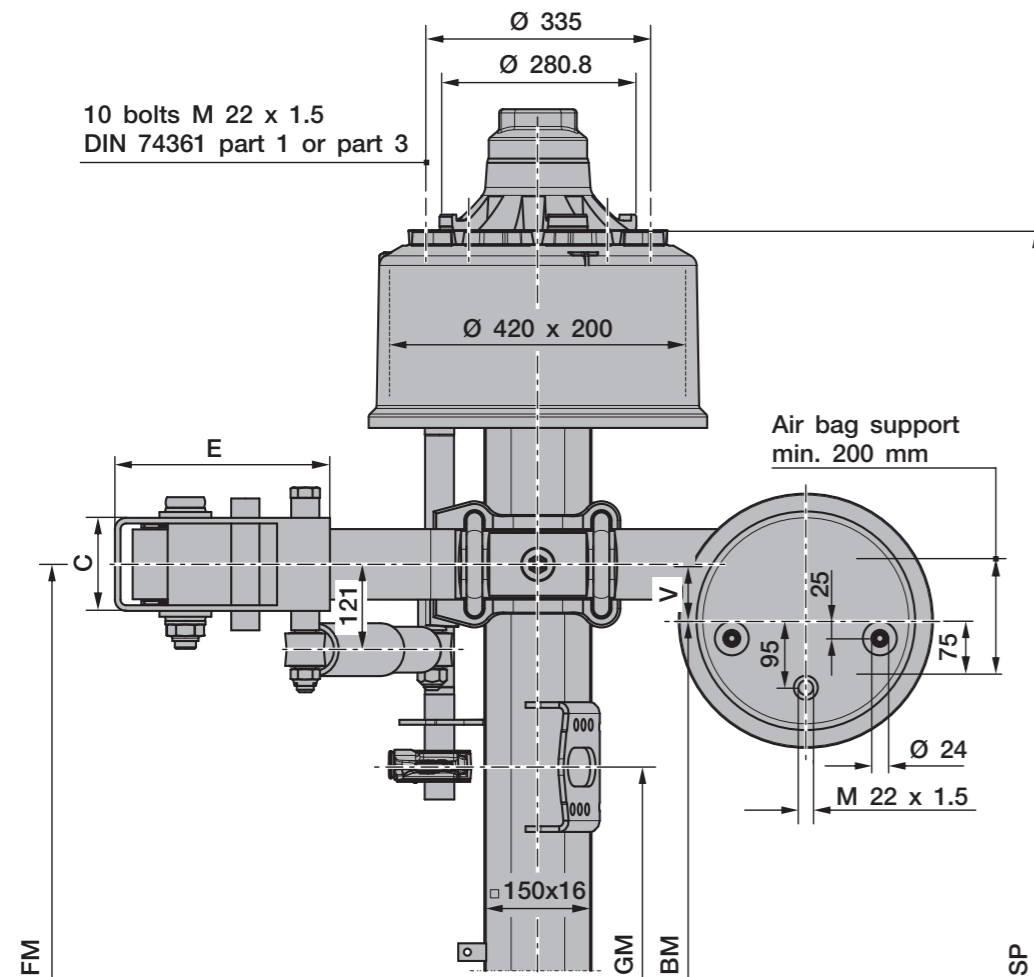

Line	Series	adjustable ride height FH					Total spring travel GF <sup>1)</sup>	Air bag type BPW	Shock absorber 02.37...	Hanger bracket				Shock absorber mounting		Packer <sup>2)</sup> B
		for single axles	for axle units	min. FH with axle raised	empty without air	loaded without air				ST	C	E	G	D	F	
1	SLO	445 - 490	455 - 490	485	385	370	190	36K	...22.83.02	268	130	305	100	170	41	---
2	SLO	475 - 520	485 - 520	515	415	400	220	36	...22.83.02	268	130	305	100	170	41	---
3	SLO	540 - 600	550 - 600	580	480	465	220	36	...22.88.02	350	130	355	100	75	115	60

<sup>1)</sup> Lifting heights acc. to TD-1242.0  
<sup>2)</sup> The packer is not included in supplied package.

Axle type	Track SP	Spring centre FM	Booster bracket centre GM	Air bag centre BM V=80	Brake cylinder <sup>3)</sup>	Tyres recommended <sup>5)</sup>
HSFSLO 12010	2040	1200	365	1040	M / F	425/65 R22,5 445/65 R22,5
		1300		1140		
HZFSLO 12010	1820	900	261	740	M / (F) <sup>4)</sup>	275/70 R22,5 <sup>6)</sup> 295/80 R22,5 <sup>7)</sup>
		980		820		

<sup>3)</sup> M = for diaphragm cylinder / F = for spring brake cylinder  
<sup>4)</sup> Use F-booster bracket with spring brake cylinder.  
<sup>5)</sup> The load rating of the tyre entered in the drawing is unrelated to the axle load capacity. It is dependent on the information from the tyre manufacturer.  
<sup>6)</sup> Track = 1820 / spring centre = 980: rim 22.5 x 7.50 with centre distance = 320 mm  
<sup>7)</sup> Tyre 295/80 R22.5 only possible with track = 1820 / spring centre = 900.

- Recommended use for BPW chassis and suspensions: As specified in current BPW warranty documents.
- Max. inclination angle of the semitrailer under full load and lowest adjustable ride height ±1°
- With trailing arm L1=500 / L2=380, bag pressures acc. to TE-1188.0 sheet 11
- The hanger brackets, air bag supports and the frame must be reinforced so that the forces applied can be absorbed. See the current BPW installation instructions.

Rev. 5 (7) 30.05.2018  
Subject to change without notice.

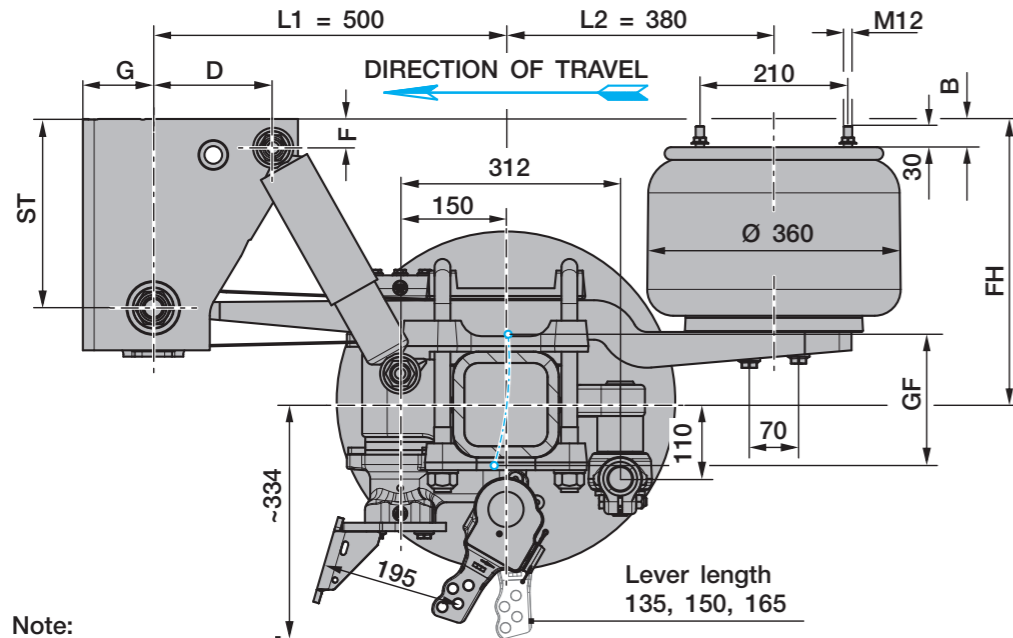

Note:  
The ground clearance  
in relation to the tyre size!

10 bolts M 22 x 1.5  
DIN 74361 part 1 or part 3

Factory setting:  
Steering angle 12°

Air bag support  
min. 200 mm

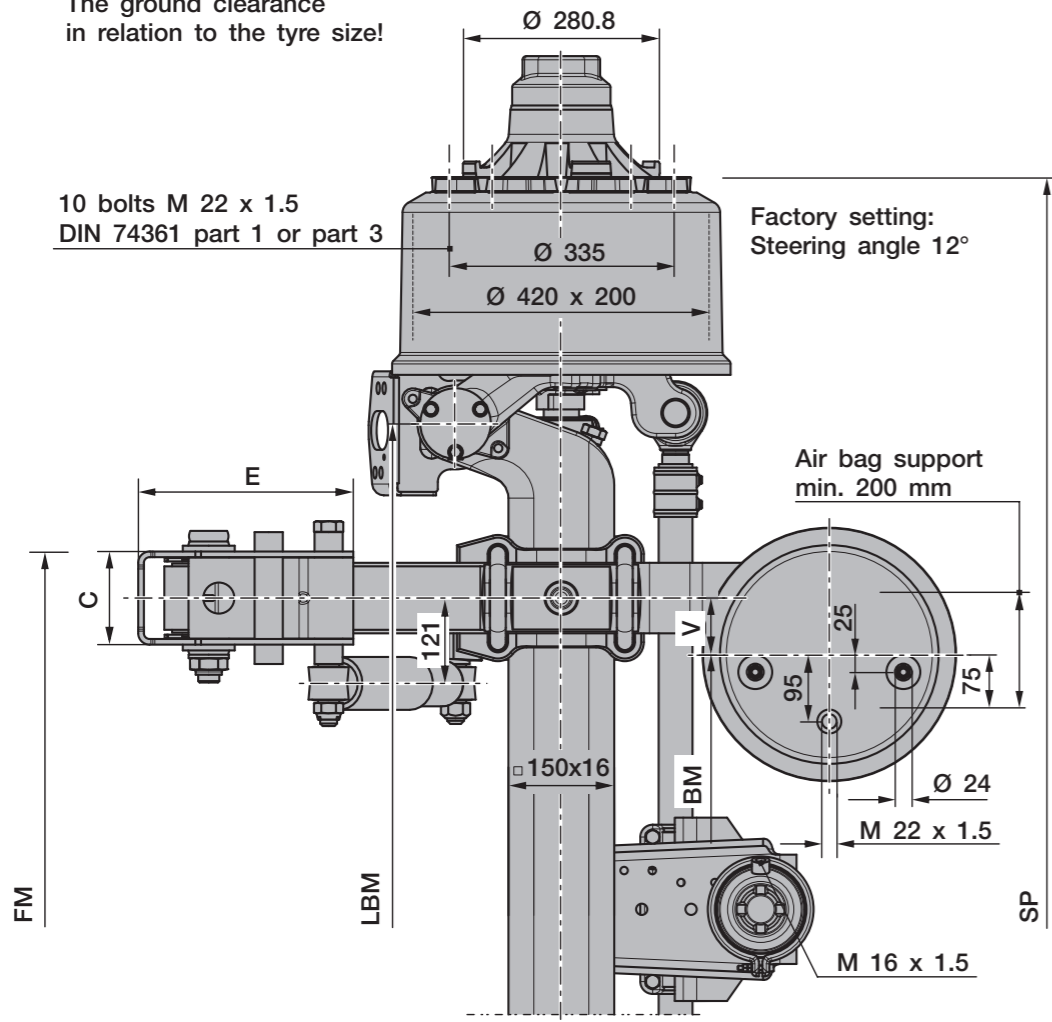

Line	Series	adjustable ride height FH				Total spring travel GF <sup>1)</sup>	Air bag type BPW	Shock absorber 02.37...	Hanger bracket				Shock absorber mounting		Packer <sup>2)</sup> B
		for axle units	min. FH with axle raised	empty without air	loaded without air				ST	C	E	G	D	F	
1	SLOLL	425 - 455	455	355	340	190	36K	...22.83.02	268	130	305	100	170	41	---
2	SLOLL	455 - 500	485	385	370	220	36	...22.83.02	268	130	305	100	170	41	---
3	SLOLL	520 - 560	550	450	435	220	36	...22.88.02	350	130	355	100	75	115	60

<sup>1)</sup> Lifting heights acc. to TD-1242.0

<sup>2)</sup> The packer is not included in supplied package.

Axle type	Track SP	Spring centre FM	Steering pivot centre LBM	Air bag centre BM V=80	Brake cylinder <sup>3)</sup>	Tyres recommended <sup>4)</sup>
HSFHSLLOL 12010	2040	980	1345	820	M / F	425/65 R22,5 445/65 R22,5
	2090	1030	1395	870		

<sup>3)</sup> M = for diaphragm cylinder / F = for spring brake cylinder

<sup>4)</sup> The load rating of the tyre entered in the drawing is unrelated to the axle load capacity. It is dependent on the information from the tyre manufacturer.

- > Recommended use for BPW chassis and suspensions: As specified in current BPW warranty documents.
- > Max. inclination angle of the semitrailer under full load and lowest adjustable ride height ±1°
- > With trailing arm L1=500 / L2=380, bag pressures acc. to TE-1188.0 sheet 11
- > The hanger brackets, air bag supports and the frame must be reinforced so that the forces applied can be absorbed. See the current BPW installation instructions.

With an axle load ratio - rigid axle to steering axle - of 1:1, in suspension units with a lifting axle and when using central lubrication systems, the steering axle must be equipped with a steering damper.

Trailing arm		Steering tie rod position	Steering damper parts kit	Drawing
L1	L2			
500	380	312 / 110	05.872.00.69.0	04.00.568461

Rev. 5 (7) 20.02.2019

Subject to change without notice.

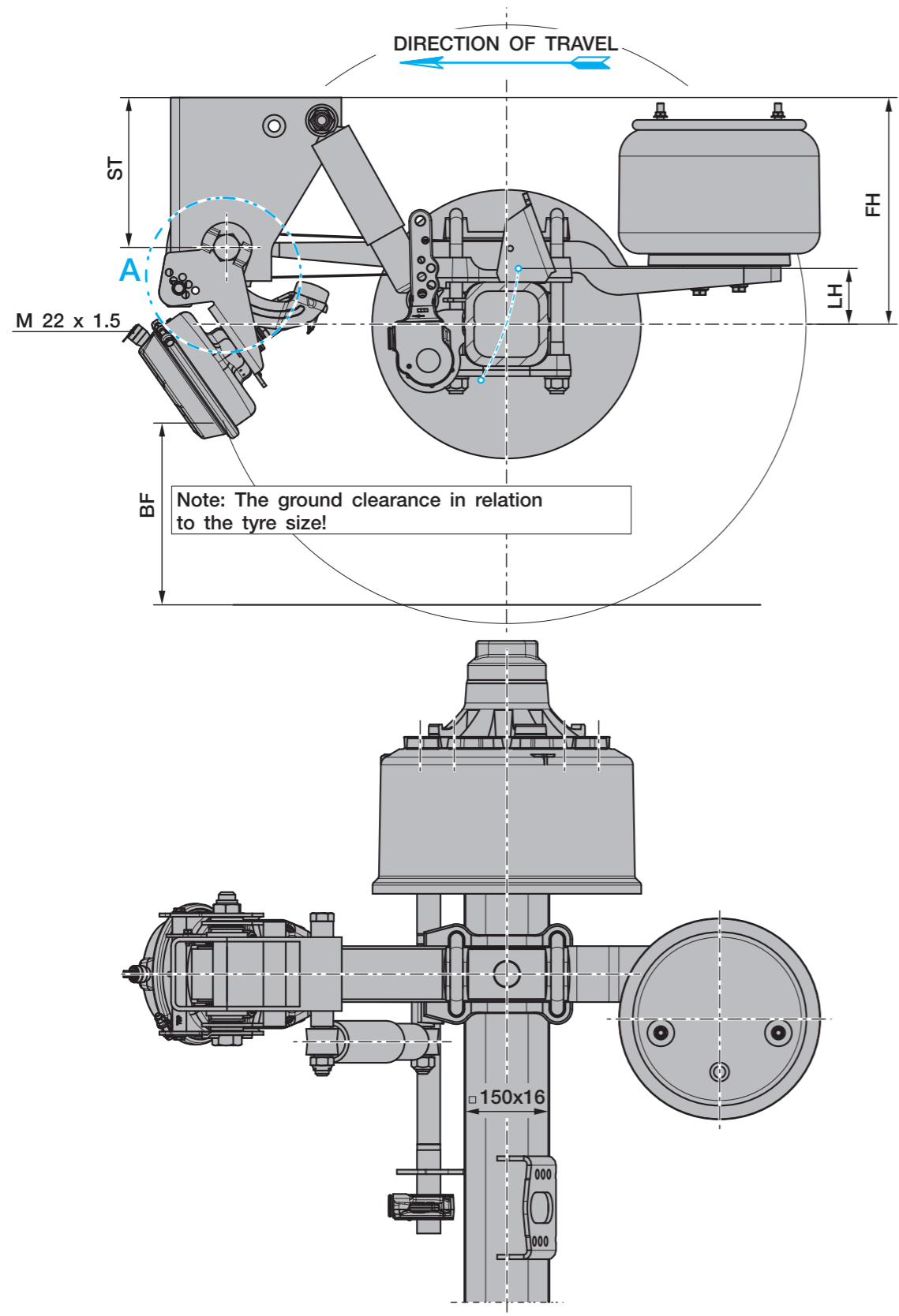

to drawing	adjustable ride height FH		min. lifting stroke LH	Hanger bracket height ST	Ground clearance BF <sup>1)</sup>	Position lift stop	BPW no. 05.828...
	for axle units	min. FH with axle raised					
Sheet 1a	425 - 455	455	100	268	379	3	...31.76.0
	455 - 500	485	100	268	409	7	
	520 - 560	550	100	350	394	7	
Sheet 2a	455 - 490	485	100	268	409	7	
	485 - 520	515	100	268	444	4	
	550 - 600	580	100	350	411	4	

<sup>1)</sup> Ground clearance in relation to the set minimum ride height with the axle raised.  
\* Tyre 445/65 R 22.5 (r<sub>stat.</sub> = 535)  
In the case of smaller tyres, it is necessary to check whether the doublesided axle lift can be used, according to the application.

Detail A

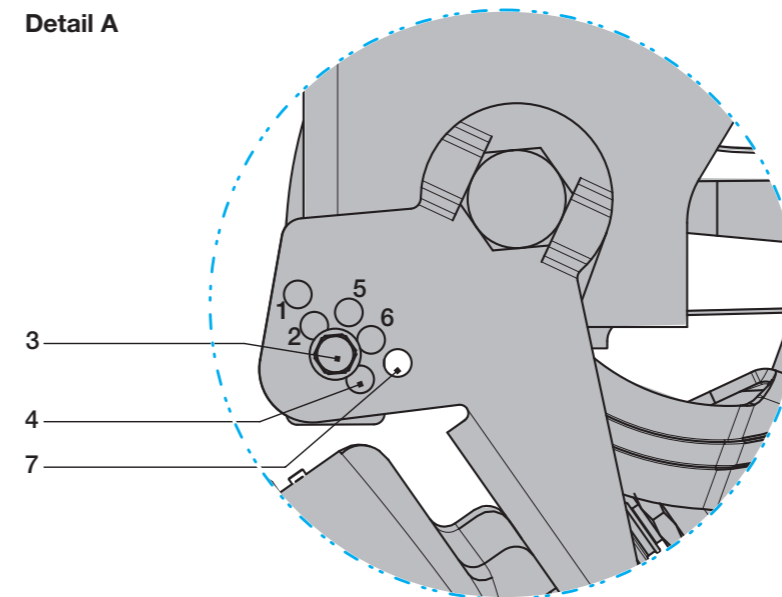

- > In the lifting and lowering version, the total spring travel must be limited by a shutoff valve.
- > Minimum air pressure for lifting the axle approx. 6 bar.
- > The hanger brackets, air bag supports and the frame must be reinforced so that the forces applied can be absorbed. See the current BPW installation instructions.

Rev. 4	(7)	30.05.2018
Subject to change without notice.		

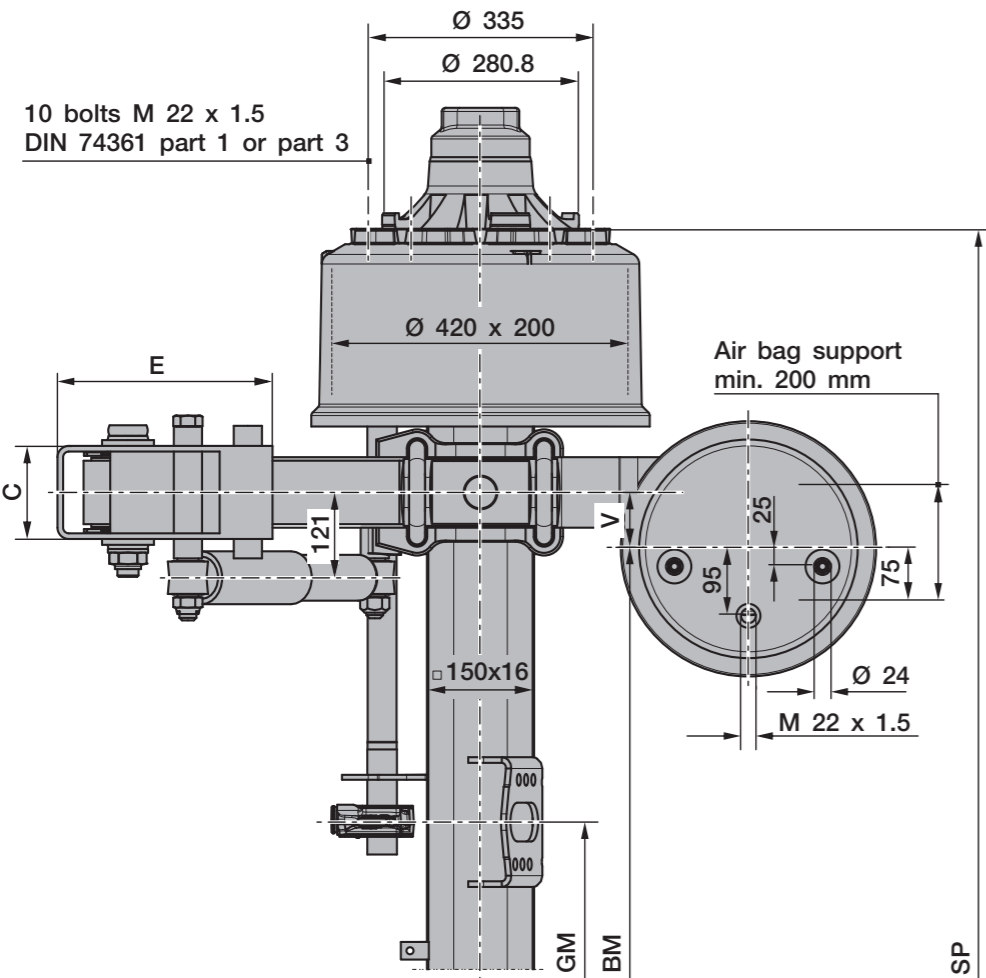
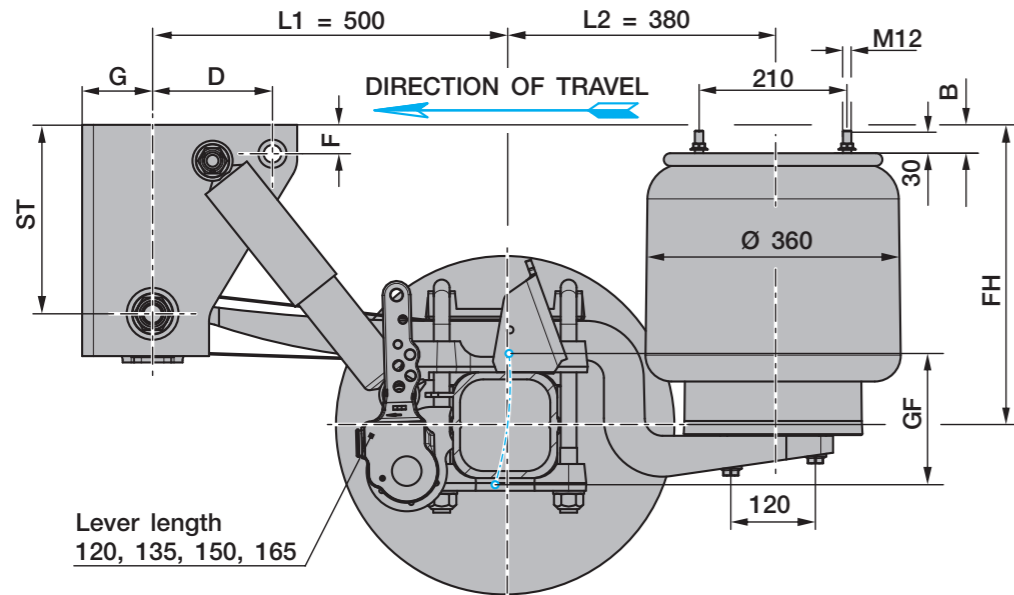

Line	Series	adjustable ride height FH					Total spring travel GF <sup>1)</sup>	Air bag type BPW	Shock absorber 02:37...	Hanger bracket				Shock absorber mounting		Packer <sup>2)</sup> B
		for single axles	for axle units	min. FH with axle raised	empty without air	loaded without air				ST	C	E	G	D	F	
1 <sup>3)</sup>	SLM	320 - 370	330 - 370	360	260	245	190	36K	...22.83.02	184	130	236	100	80	37	---
2 <sup>3)</sup>	SLM	345 - 415	355 - 415	385	285	270	220	36	...22.83.02	184	130	236	100	80	37	---
3	SLM	375 - 445	385 - 445	415	315	300	220	36	...22.83.02	268	130	305	100	85	51	---
4	SLM	410 - 460	420 - 460	450	350	335	220	36	...22.83.02	268	130	305	100	170	41	60
5	SLM	435 - 500	445 - 500	475	375	360	220	36	...22.83.02	268	130	305	100	170	41	100

<sup>1)</sup> Lifting heights acc. to TD-1242.0  
<sup>2)</sup> The packer is not included in supplied package.  
<sup>3)</sup> Only suitable for semitrailer / centre axle drawbar trailer

Axle type	Track SP	Spring centre FM	Booster bracket centre GM	Air bag centre BM V=80	Brake cylinder <sup>4)</sup>	Tyres recommended <sup>6)</sup>
HSFSLM 12010	2040	1200	365	1040	M / F	425/65 R22,5 445/65 R22,5
		1300		1140		
HZFSLM 12010	1820	900	261	740	M / (F) <sup>5)</sup>	275/70 R22,5 <sup>7)</sup> 295/80 R22,5 <sup>8)</sup>
		980		820		

<sup>4)</sup> M = for diaphragm cylinder / F = for spring brake cylinder  
<sup>5)</sup> Use F-booster bracket with spring brake cylinder.  
<sup>6)</sup> The load rating of the tyre entered in the drawing is unrelated to the axle load capacity. It is dependent on the information from the tyre manufacturer.  
<sup>7)</sup> Track = 1820 / spring centre = 980: rim 22.5 x 7.50 with centre distance = 320 mm  
<sup>8)</sup> Tyres 295/80 R 22.5 only possible with track = 1820 / spring centre = 900

- Recommended use for BPW chassis and suspensions: As specified in current BPW warranty documents.
- Max. inclination angle of the semitrailer under full load and lowest adjustable ride height ±1°
- With trailing arm L1=500 / L2=380, bag pressures acc. to TE-1188.0 sheet 11
- The hanger brackets, air bag supports and the frame must be reinforced so that the forces applied can be absorbed. See the current BPW installation instructions.

Rev. 3 (7) 16.11.2016  
Subject to change without notice.

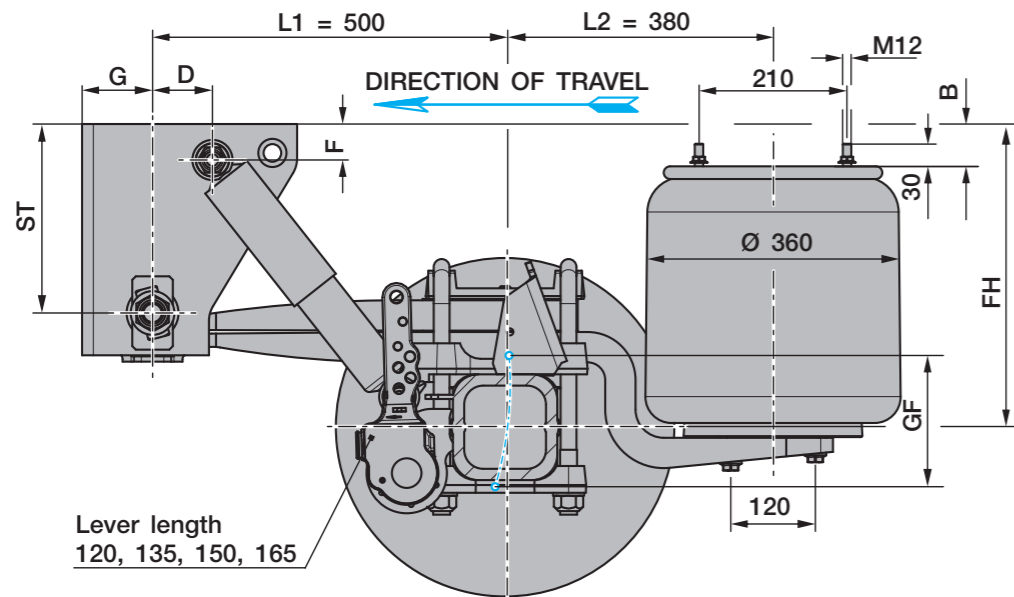

Line	Series	adjustable ride height FH					Total spring travel GF <sup>1)</sup>	Air bag type BPW	Shock absorber 02.37...	Hanger bracket				Shock absorber mounting		Packer <sup>2)</sup> B
		for single axles	for axle units	min. FH with axle raised	empty without air	loaded without air				ST	C	E	G	D	F	
1 <sup>3)</sup>	SLM	350 - 410	360 - 410	390	290	275	220	36	...22.83.02	184	130	236	100	80	37	---
2	SLM	380 - 440	390 - 440	420	320	305	220	36	...22.83.02	268	130	305	100	85	51	---
3	SLM	410 - 460	420 - 460	450	350	335	220	36	...22.83.02	268	130	305	100	85	51	60
4	SLM	440 - 500	450 - 500	480	380	365	220	36	...22.83.02	268	130	305	100	85	51	100

<sup>1)</sup> Lifting heights acc. to TD-1242.0  
<sup>2)</sup> The packer is not included in supplied package.  
<sup>3)</sup> Only suitable for semitrailer / centre axle drawbar trailer

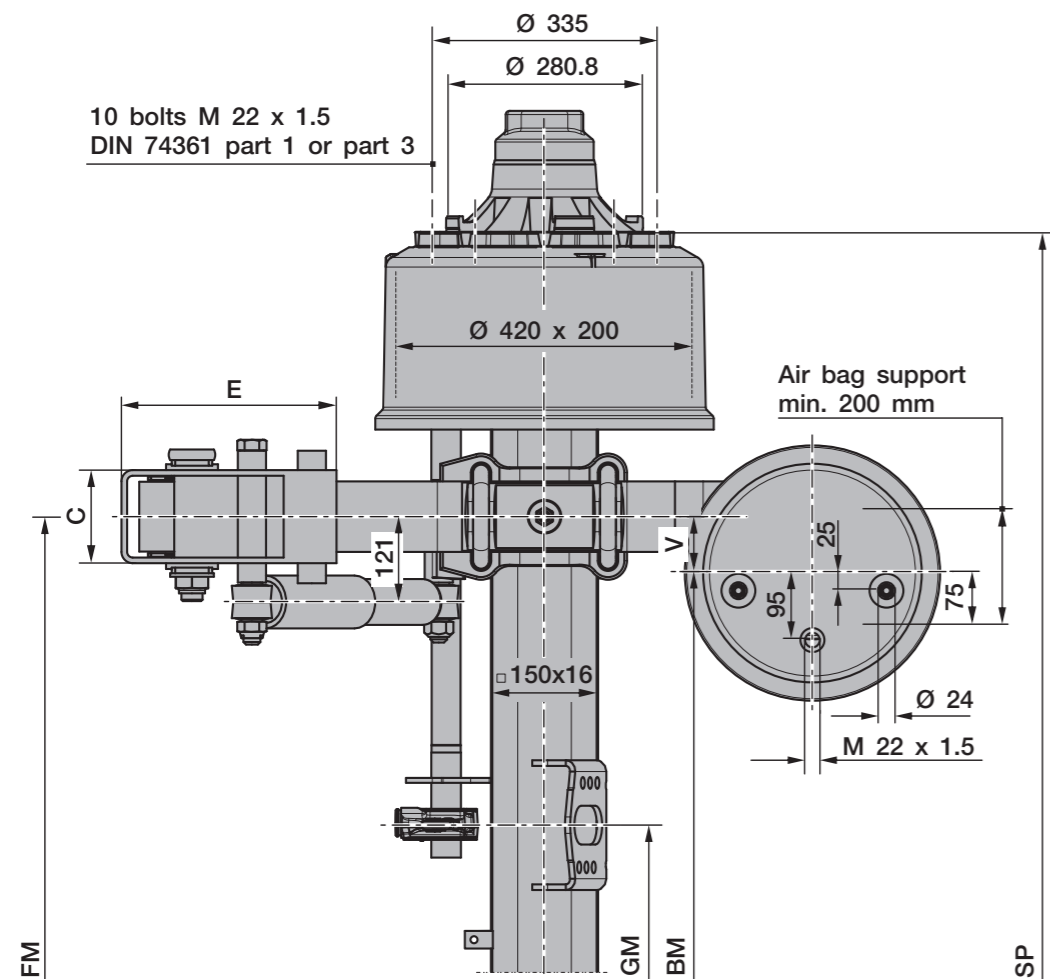

Axle type	Track SP	Spring centre FM	Booster bracket centre GM	Air bag centre BM V=80	Brake cylinder <sup>4)</sup>	Tyres recommended <sup>6)</sup>
HSFSLM 12010	2040	1200	365	1040	M / F	425/65 R22,5 445/65 R22,5
		1300		1140		
HZFSLM 12010	1820	900	261	740	M / (F) <sup>5)</sup>	275/70 R22,5 <sup>7)</sup> 295/80 R22,5 <sup>8)</sup>
		980		820	M / F	

<sup>4)</sup> M = for diaphragm cylinder / F = for spring brake cylinder  
<sup>5)</sup> Use F-booster bracket with spring brake cylinder.  
<sup>6)</sup> The load rating of the tyre entered in the drawing is unrelated to the axle load capacity. It is dependent on the information from the tyre manufacturer.  
<sup>7)</sup> Track = 1820 / spring centre = 980: rim 22.5 x 7.50 with centre distance = 320 mm  
<sup>8)</sup> Tyres 295/80 R 22.5 only possible with track = 1820 / spring centre = 900

- Recommended use for BPW chassis and suspensions: As specified in current BPW warranty documents.
- Max. inclination angle of the semitrailer under full load and lowest adjustable ride height ±1°
- With trailing arm L1=500 / L2=380, bag pressures acc. to TE-1188.0 sheet 11
- The hanger brackets, air bag supports and the frame must be reinforced so that the forces applied can be absorbed. See the current BPW installation instructions.

Rev. 3 (7) 16.11.2016  
Subject to change without notice.

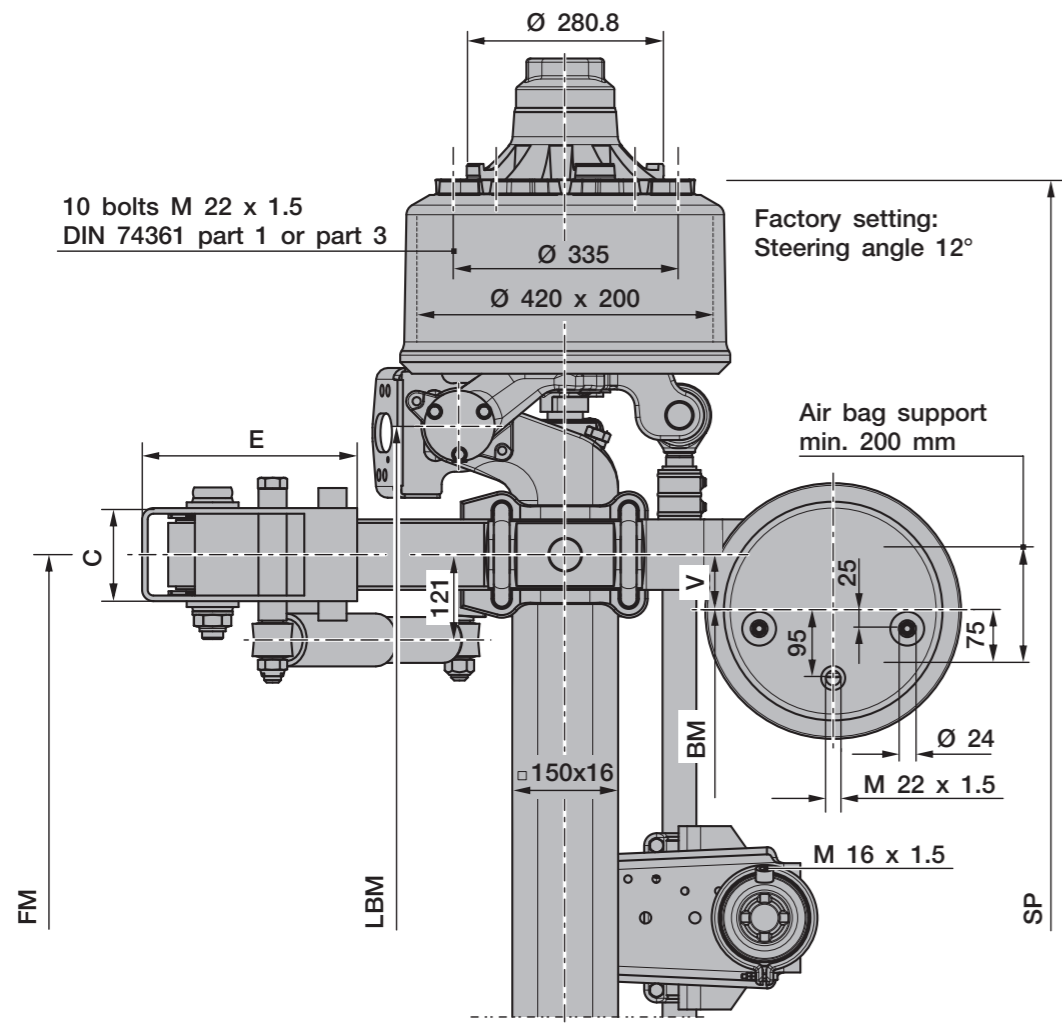
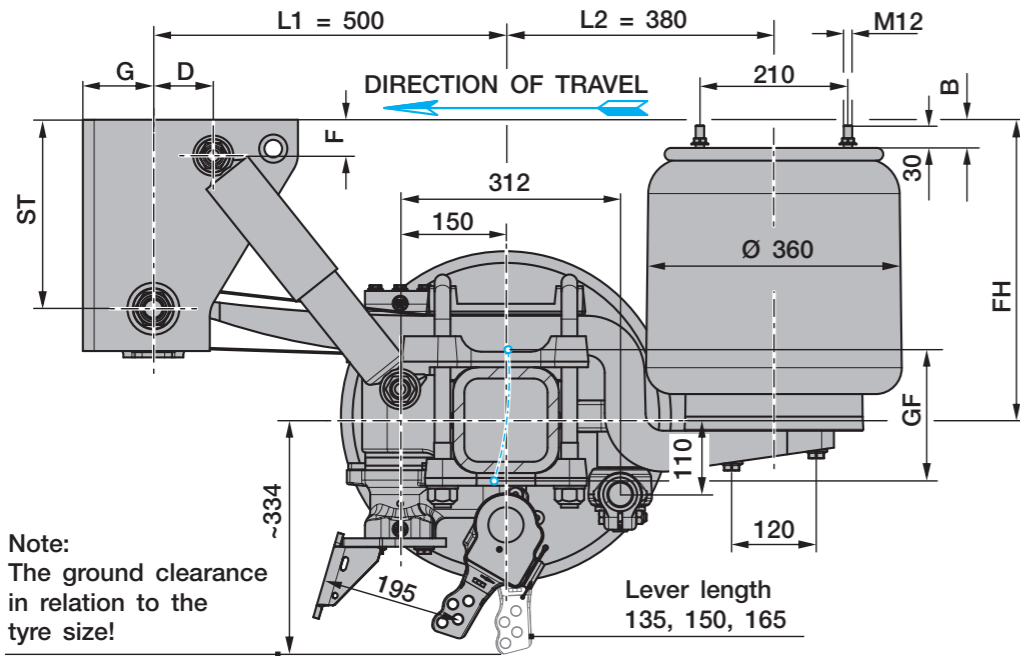

Line	Series	adjustable ride height FH				Total spring travel GF <sup>1)</sup>	Air bag type BPW	Shock absorber 02.37...	Hanger bracket				Shock absorber mounting		Packer <sup>2)</sup> B
		for axle units	min. FH with axle raised	empty without air	loaded without air				ST	C	E	G	D	F	
1	SLMLL	330 - 370	360	260	245	190	36K	...22.83.02	184	130	236	100	80	37	---
2	SLMLL	355 - 415	385	285	270	220	36	...22.83.02	184	130	236	100	80	37	---
3	SLMLL	385 - 445	415	315	300	220	36	...22.83.02	268	130	305	100	85	51	---
4	SLMLL	420 - 460	450	350	335	220	36	...22.83.02	268	130	305	100	170	41	60
5	SLMLL	445 - 500	475	375	360	220	36	...22.83.02	268	130	305	100	170	41	100

<sup>1)</sup> Lifting heights acc. to TD-1242.0  
<sup>2)</sup> The packer is not included in supplied package.

Axle type	Track SP	Spring centre FM	Steering pivot centre LBM	Air bag centre BM V=80	Brake cylinder <sup>3)</sup>	Tyres recommended <sup>4)</sup>
HSFHSLMLL 12010	2040	980	1345	820	M / F	425/65 R22,5 445/65 R22,5
	2090	1030	1395	870		

<sup>3)</sup> M = for diaphragm cylinder / F = for spring brake cylinder

<sup>4)</sup> The load rating of the tyre entered in the drawing is unrelated to the axle load capacity. It is dependent on the information from the tyre manufacturer.

- Recommended use for BPW chassis and suspensions: As specified in current BPW warranty documents.
- Max. inclination angle of the semitrailer under full load and lowest adjustable ride height ±1°
- With trailing arm L1=500 / L2=380, bag pressures acc. to TE-1188.0 sheet 11
- The hanger brackets, air bag supports and the frame must be reinforced so that the forces applied can be absorbed. See the current BPW installation instructions.

With an axle load ratio - rigid axle to steering axle - of 1:1, in suspension units with a lifting axle and when using central lubrication systems, the steering axle must be equipped with a steering damper.

Trailing arm		Steering tie rod position	Steering damper parts kit	Drawing
L1	L2			
500	380	312 / 110	05.872.00.69.0	04.00.568461

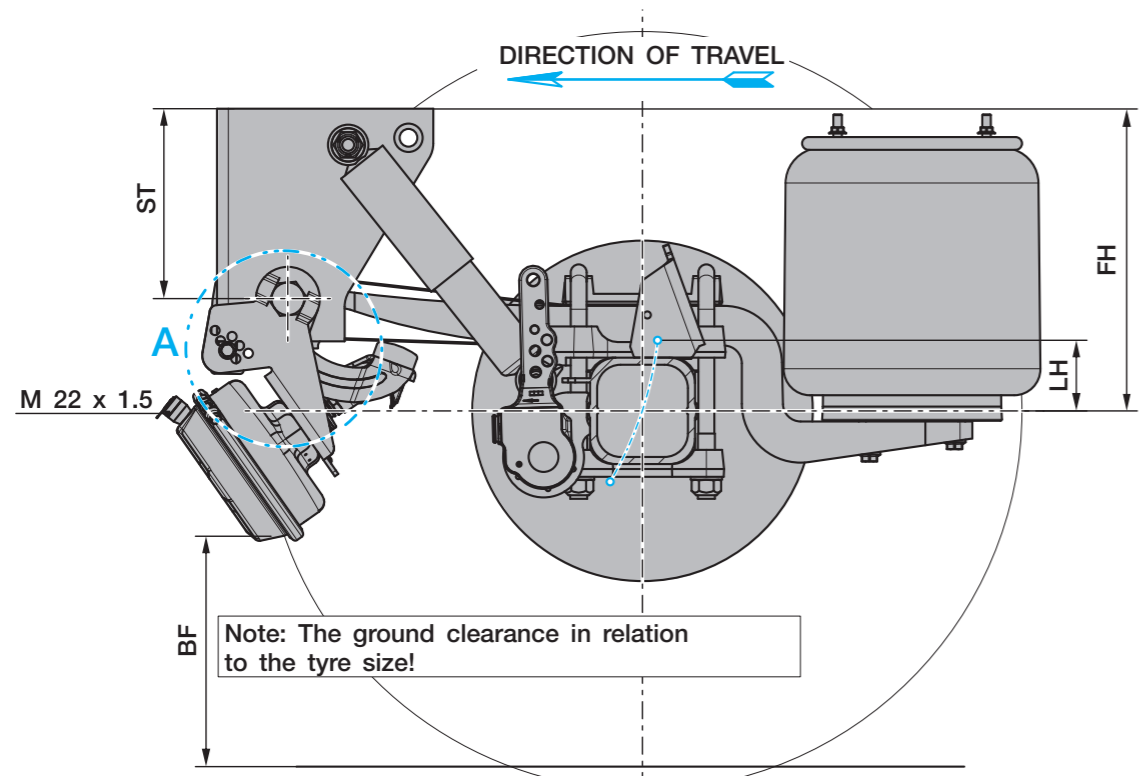

to drawing	adjustable ride height FH		min. lifting stroke LH	Hanger bracket height ST	Ground clearance BF <sup>1)</sup>	Position lift stop	BPW no. 05.828...
	for axle units	min. FH with axle raised					
Sheet 8a	330 - 370	360	100	184	374	3	...31.76.0
	355 - 415	385	100	184	404	7	
	385 - 445	415	100	268	344	3	
	420 - 460	450	100	268	379	7	
	445 - 500	475	100	268	404	4	
Sheet 9a	360 - 410	390	100	184	404	4	
	390 - 440	420	100	268	344	7	
	420 - 460	450	100	268	379	4	
	450 - 500	480	100	268	409	4	

<sup>1)</sup> Ground clearance in relation to the set minimum ride height with the axle raised.  
\* Tyre 445/65 R 22.5 (r<sub>stat.</sub> = 535)  
In the case of smaller tyres, it is necessary to check whether the doublesided axle lift can be used, according to the application.

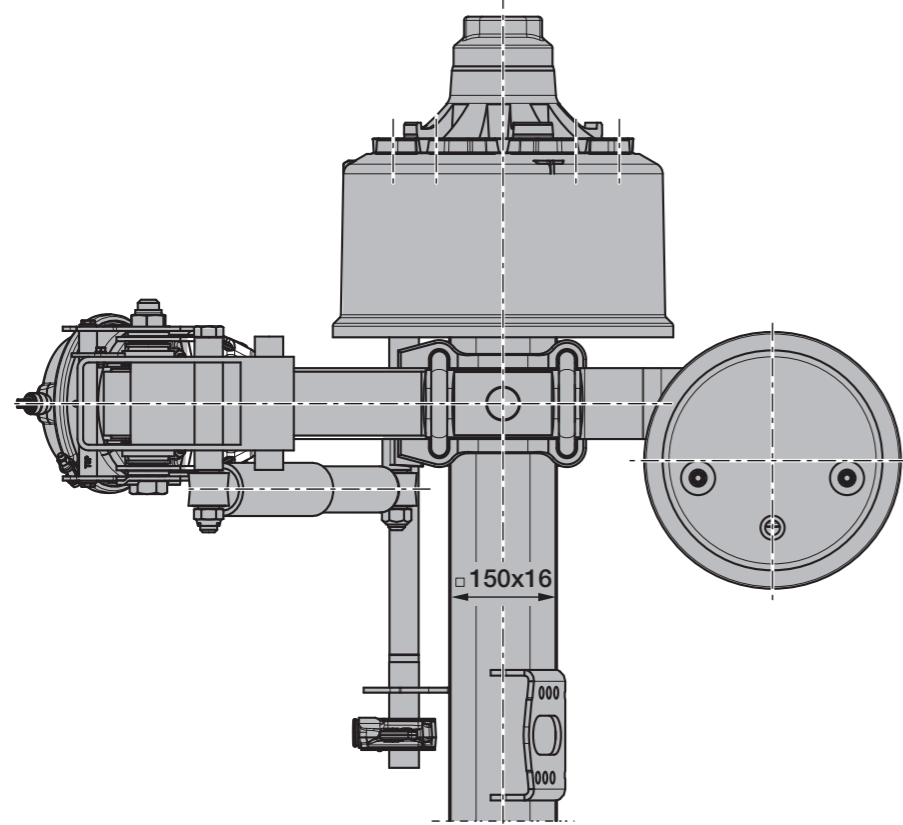

Detail A

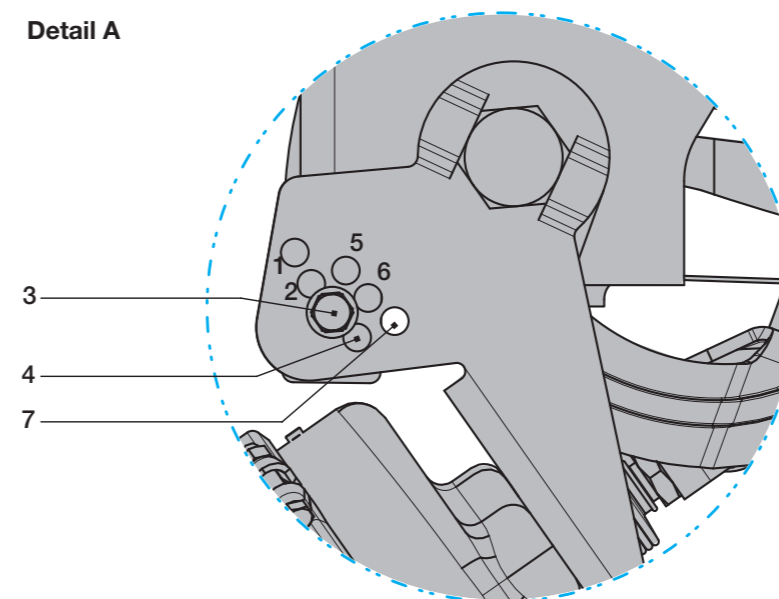

- > In the lifting and lowering version, the total spring travel must be limited by a shutoff valve.
- > Minimum air pressure for lifting the axle approx. 6 bar.
- > The hanger brackets, air bag supports and the frame must be reinforced so that the forces applied can be absorbed. See the current BPW installation instructions.

Rev. 3	(7)	16.11.2016
Subject to change without notice.		

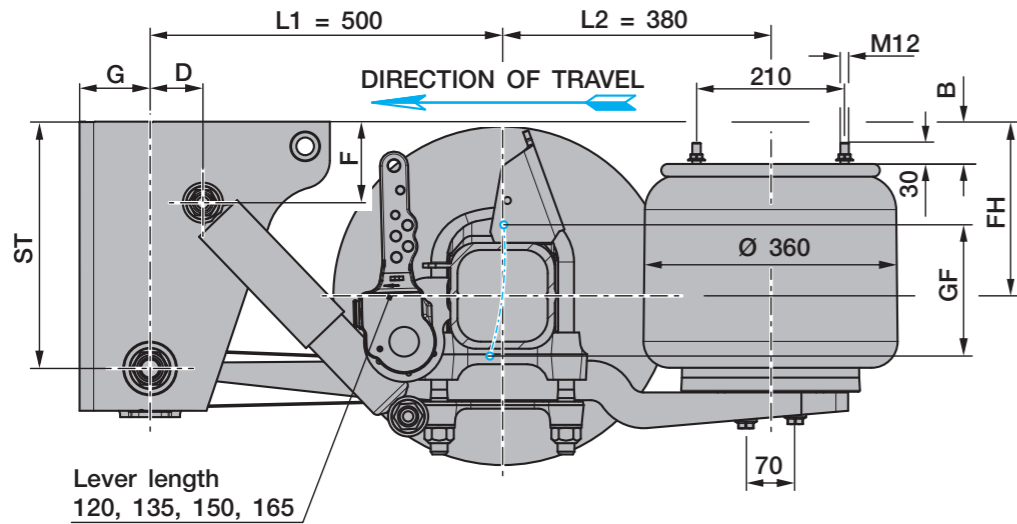

10 bolts M 22 x 1.5  
DIN 74361 part 1 or part 3

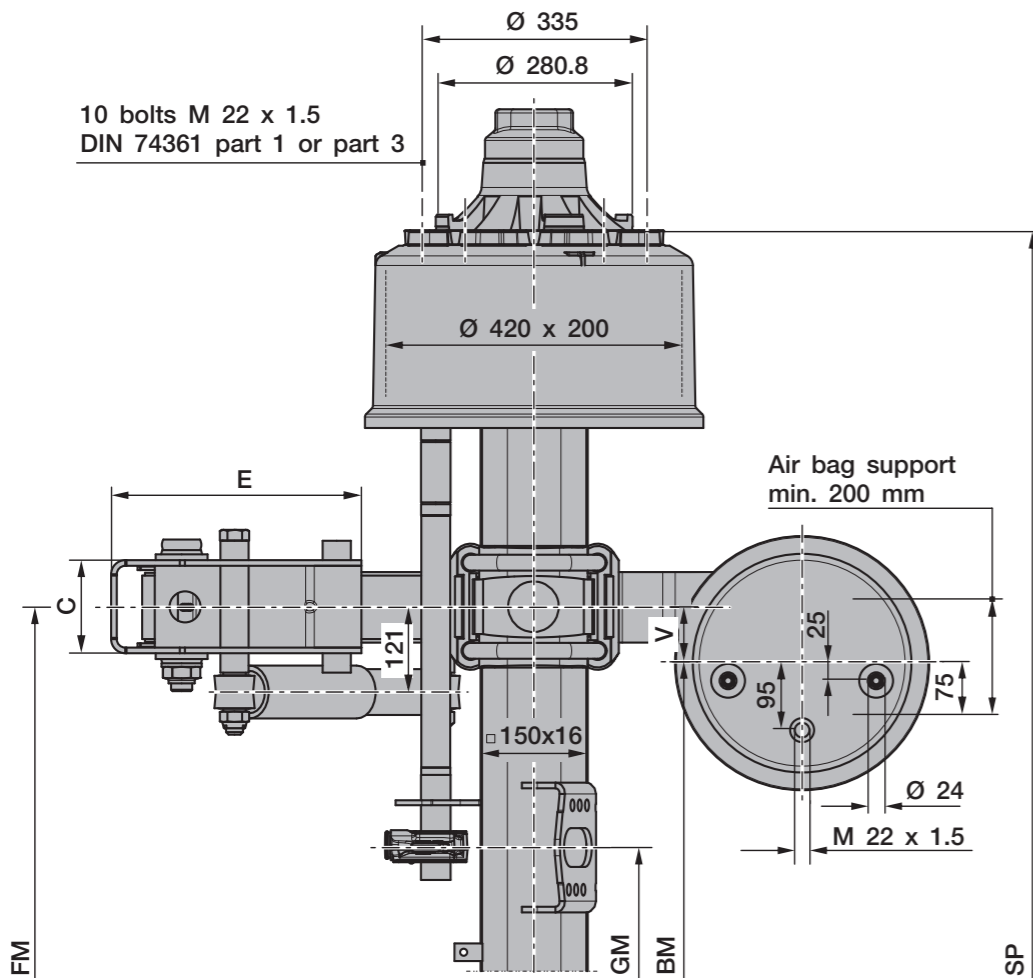

Line	Series	adjustable ride height FH					Total spring travel GF <sup>1)</sup>	Air bag type BPW	Shock absorber 02.37...	Hanger bracket				Shock absorber mounting		Packer <sup>2)</sup> B
		for single axles	for axle units	min. FH with axle raised	empty without air	loaded without air				ST	C	E	G	D	F	
1	SLU	235 - 295	245 - 295	275	175	160	220	36	...22.88.02	350	130	355	100	75	115	---
2	SLU	270 - 315	280 - 315	310	210	195	220	36	...22.88.02	350	130	355	100	75	115	60
3	SLU	290 - 335	300 - 335	330	230	215	220	36	...22.88.02	350	130	355	100	75	115	100

<sup>1)</sup> Lifting heights acc. to TD-1242.0

<sup>2)</sup> The packer is not included in supplied package.

Axle type	Track SP	Spring centre FM	Booster bracket centre GM	Air bag centre BM V=80	Brake cylinder <sup>3)</sup>	Tyres recommended <sup>5)</sup>
HSFSLU 12010	2040	1200	365	1040	M / F	425/65 R22,5 445/65 R22,5
		1300		1140		
HZFSLU 12010	1820	900	261	740	M / (F) <sup>4)</sup>	275/70 R22,5 <sup>6)</sup> 295/80 R22,5 <sup>7)</sup>
		980		820		

<sup>3)</sup> M = for diaphragm cylinder / F = for spring brake cylinder

<sup>4)</sup> Use F-booster bracket with spring brake cylinder.

<sup>5)</sup> The load rating of the tyre entered in the drawing is unrelated to the axle load capacity. It is dependent on the information from the tyre manufacturer.

<sup>6)</sup> Track = 1820 / spring centre = 980: rim 22.5 x 7.50 with centre distance = 320 mm

<sup>7)</sup> Tyres 295/80 R 22.5 only possible with track = 1820 / spring centre = 900

- Recommended use for BPW chassis and suspensions: As specified in current BPW warranty documents.
- Max. inclination angle of the semitrailer under full load and lowest adjustable ride height ±1°
- With trailing arm L1=500 / L2=380, bag pressures acc. to TE-1188.0 sheet 11
- The hanger brackets, air bag supports and the frame must be reinforced so that the forces applied can be absorbed. See the current BPW installation instructions.

Rev. 5 (7) 01.02.2018

Subject to change without notice.

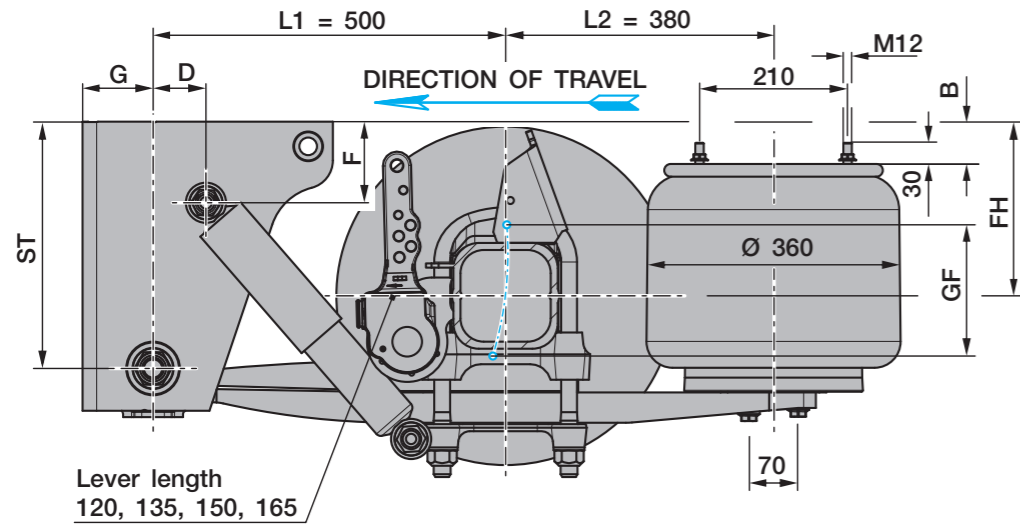

10 bolts M 22 x 1.5  
DIN 74361 part 1 or part 3

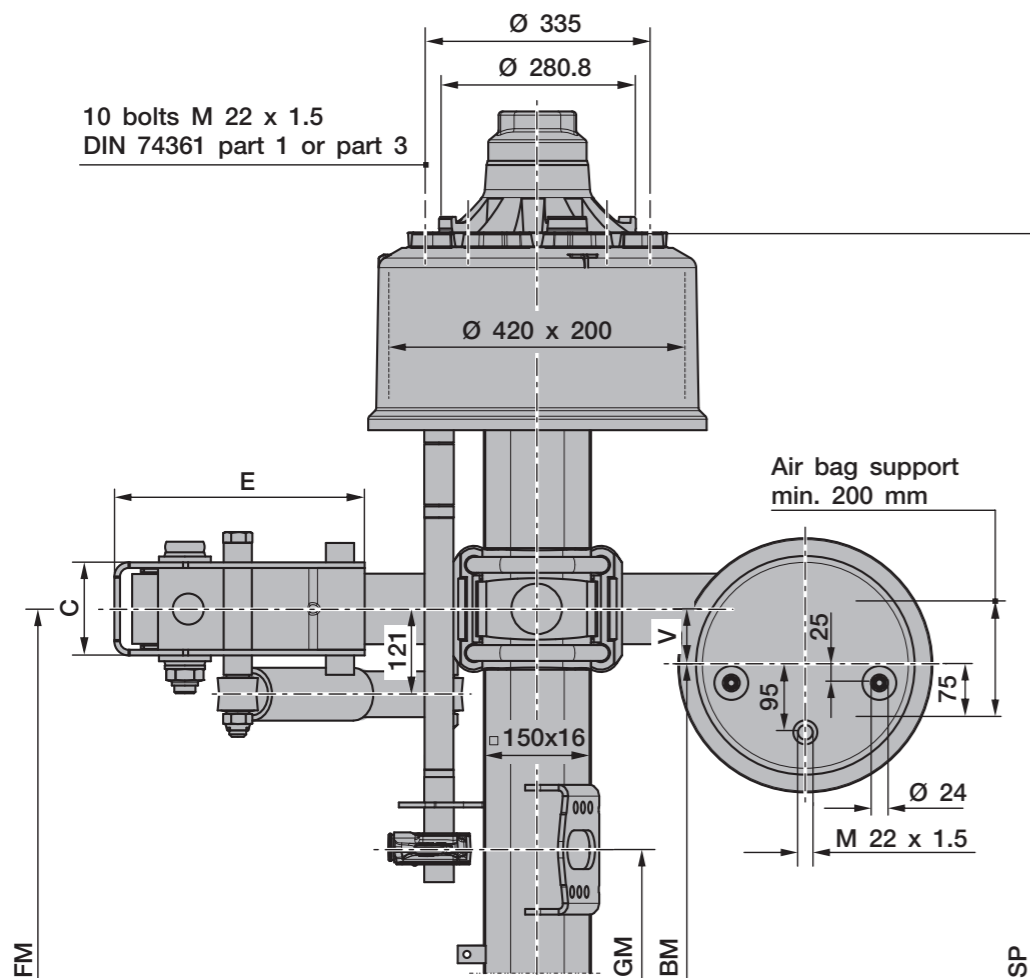

Line	Series	adjustable ride height FH					Total spring travel GF <sup>1)</sup>	Air bag type BPW	Shock absorber 02.37...	Hanger bracket				Shock absorber mounting		Packer <sup>2)</sup> B
		for single axles	for axle units	min. FH with axle raised	empty without air	loaded without air				ST	C	E	G	D	F	
1	SLU	235 - 295	245 - 295	275	175	160	220	36	...22.88.02	350	130	355	100	75	115	---
2	SLU	270 - 315	280 - 315	310	210	195	220	36	...22.88.02	350	130	355	100	75	115	60
3	SLU	290 - 335	300 - 335	330	230	215	220	36	...22.88.02	350	130	355	100	75	115	100

<sup>1)</sup> Lifting heights acc. to TD-1242.0

<sup>2)</sup> The packer is not included in supplied package.

Axle type	Track SP	Spring centre FM	Booster bracket centre GM	Air bag centre BM V=80	Brake cylinder <sup>3)</sup>	Tyres recommended <sup>5)</sup>
HSFSLU 12010	2040	1200	365	1040	M / F	425/65 R22,5 445/65 R22,5
		1300		1140		
HZFSLU 12010	1820	900	261	740	M / (F) <sup>4)</sup>	275/70 R22,5 <sup>6)</sup> 295/80 R22,5 <sup>7)</sup>
		980		820		

<sup>3)</sup> M = for diaphragm cylinder / F = for spring brake cylinder

<sup>4)</sup> Use F-booster bracket with spring brake cylinder.

<sup>5)</sup> The load rating of the tyre entered in the drawing is unrelated to the axle load capacity. It is dependent on the information from the tyre manufacturer.

<sup>6)</sup> Track = 1820 / spring centre = 980: rim 22.5 x 7.50 with centre distance = 320 mm

<sup>7)</sup> Tyres 295/80 R 22.5 only possible with track = 1820 / spring centre = 900

- Recommended use for BPW chassis and suspensions: As specified in current BPW warranty documents.
- Max. inclination angle of the semitrailer under full load and lowest adjustable ride height ±1°
- With trailing arm L1=500 / L2=380, bag pressures acc. to TE-1188.0 sheet 11
- The hanger brackets, air bag supports and the frame must be reinforced so that the forces applied can be absorbed. See the current BPW installation instructions.

Rev. 5 (7) 01.02.2018

Subject to change without notice.

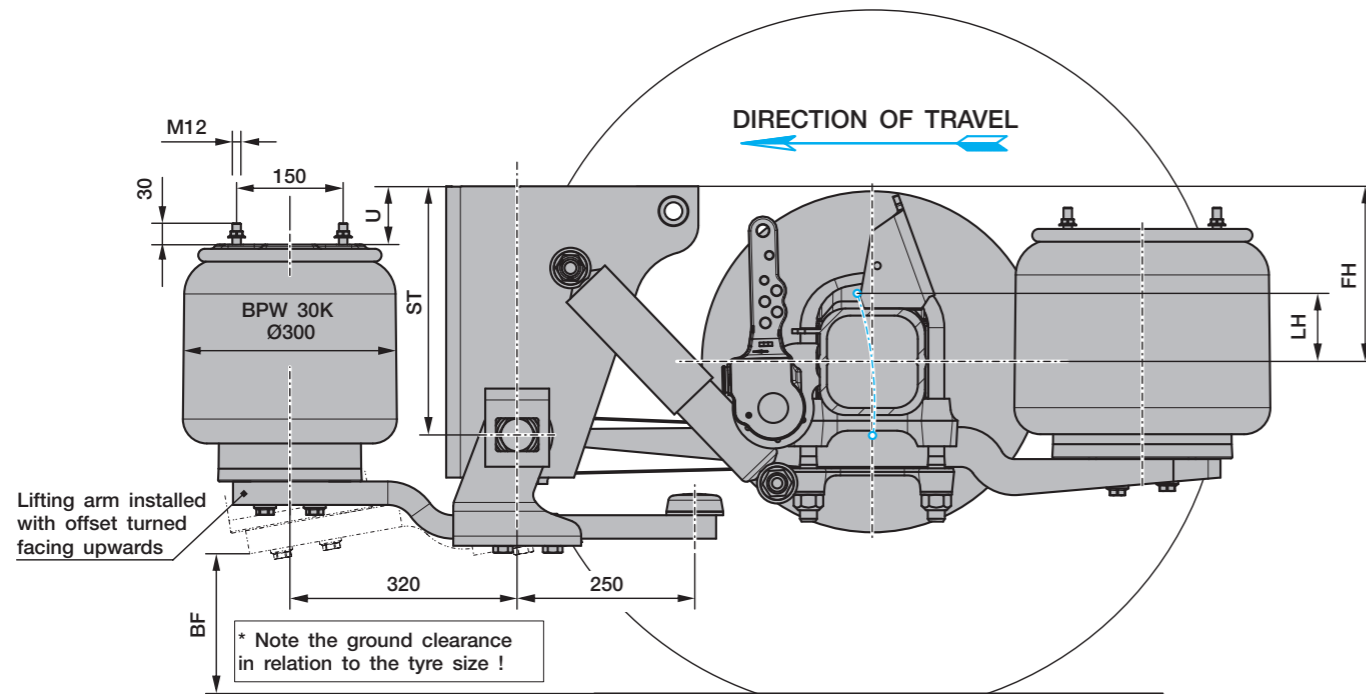

to drawing	adjustable ride height FH		min. lifting stroke LH	Hanger bracket height ST	Ground clearance BF <sup>1)</sup>	Packer U <sup>4)</sup>	BPW no. 05.828...
	for axle units	min. FH with axle raised					
Sheet 15a	245 - 295 <sup>3)</sup>	275	100	350	225	100	...31.04.0
	280 - 315 <sup>3)</sup>	310	100	350	284	60	
	300 - 335 <sup>3)</sup>	330	100	350	323	60	
Sheet 16a	245 - 295 <sup>3)</sup>	275	100	350	281	40	
	280 - 315 <sup>2)</sup>	310	100	350	248	100	
	300 - 335 <sup>2)</sup>	330	100	350	284	100	

- <sup>1)</sup> Ground clearance in relation to the set minimum ride height with the axle raised.  
\* Tyre 445/65 R 22.5 (r<sub>stat.</sub> = 535)  
In the case of smaller tyres, it is necessary to check whether the doublesided axle lift can be used, according to the application.
- <sup>2)</sup> Lifting arm installed with offset turned facing downwards.
- <sup>3)</sup> Lifting arm installed with offset turned facing upwards.
- <sup>4)</sup> The packer is not included in supplied package.

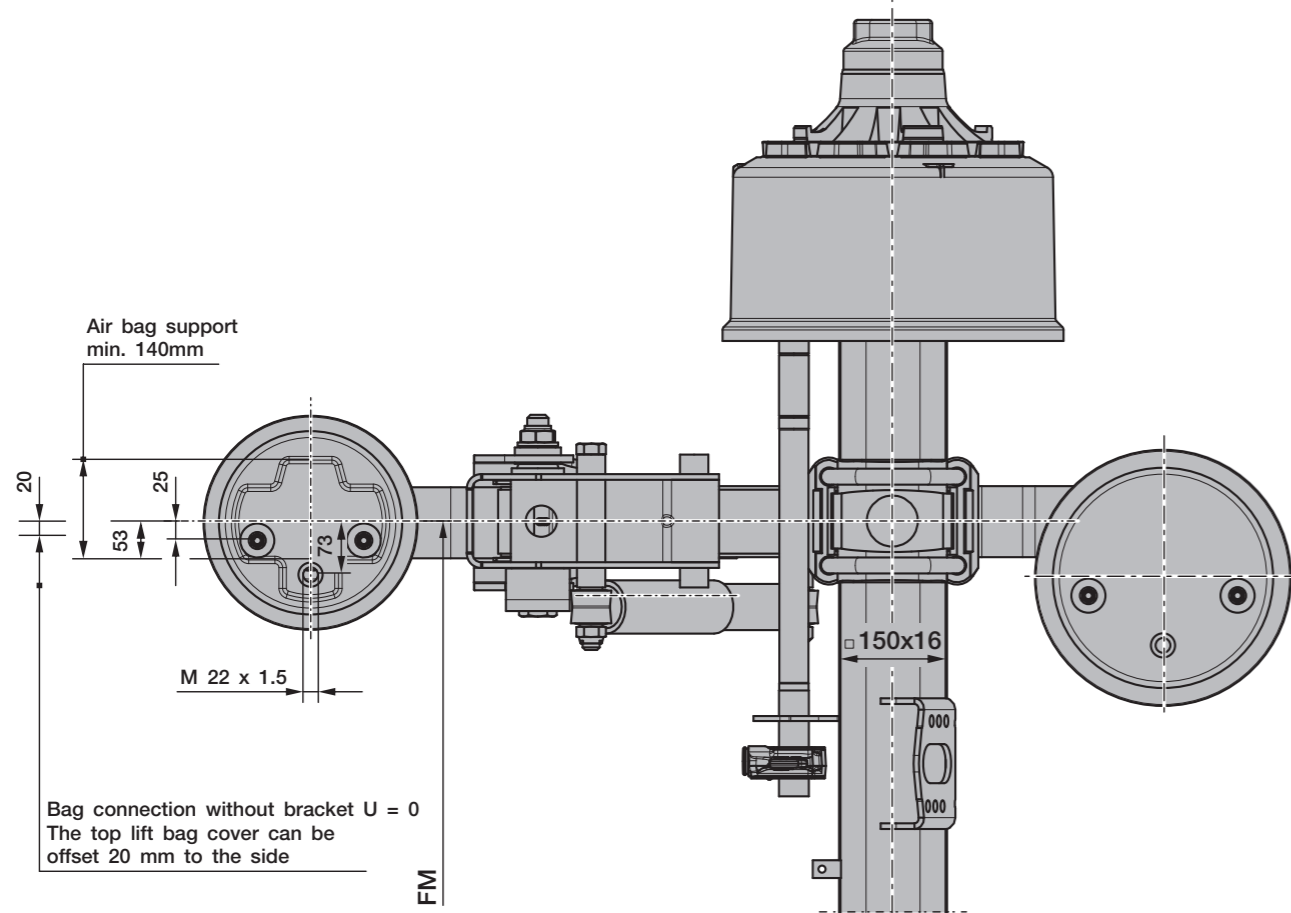

- The air pressure for the lift bag must be limited to 5 bar with a reduction valve.
- The hanger brackets, air bag supports and the frame must be reinforced so that the forces applied can be absorbed. See the current BPW installation instructions.

Rev. 4	(7)	16.11.2016
Subject to change without notice.		